

## *Update on NAF Funded Research*

Laura Ranum, Ph.D.  
Professor of Molecular Genetics and Microbiology  
Director Center for NeuroGenetics  
University of Florida

# Goals and Impact of NAF Funding

- Birds-Eye View of Funding Portfolio
  - Making scientific connections between diseases
  - Encouraging young investigators to pursue ataxia research
- Some Examples
  - Genetics 101-2015
  - Four Pioneer Awards
  - Therapeutic strategies to fight ataxia
  - Connections between scientists, diseases, NIH and Industry

# NAF Seed Grant Recipients in 2014

## RESEARCH SEED MONEY AWARDS

SCA1  
AOA2  
Glutamate  
Database  
SCA36  
Sleep  
SCA3  
AD sensory ataxia

**Hampe, Christiane S., Ph.D.**

University of Washington, Seattle, WA  
Glutamate Decarboxylase in Cerebellar Ataxia

**Kim, Do-Hyung, Ph.D. (in Partnership with the Bob Allison Ataxia Research Center)**

University of Minnesota, Minneapolis, MN  
Pathological and therapeutic roles of immunoproteasomes in SCA1

**Lim, Janghoo, Ph.D.**

Yale University, New Haven, CT  
Molecular pathogenesis studies of spinocerebellar ataxia type 1

**Manley, James L. Ph.D.**

Columbia University, New York, NY  
Functions of Senataxin, product of the AOA2 target gene SETX, in autophagy and lysosome function.

**Perlman, Susan, M.D.**

University of California Los Angeles, CA  
National Ataxia Database

**Rossoll, Wilfried, Ph.D.**

Emory University School of Medicine, Atlanta GA  
SCA36 patient stem cell-derived neurons to study disease mechanisms and develop novel therapeutic strategies

**Schmahmann, Jeremy, M.D.**

Massachusetts General Hospital, Boston, MA  
The Nature and Impact of Sleep Dysfunction in Cerebellar Ataxias

**Teixeira-Castro, Andreia, Ph.D.**

University of Minho, Braga, Portugal  
Determinants of neuron-specific pathogenesis: study in a C. elegans model of SCA3

**Wojcikiewicz, Richard, Ph.D.**

# NAF Grant Recipients

## Young Investigators in 2014

### INVESTING IN THE NEXT GENERATION OF ATAXIA RESEARCHERS

Brain Function  
Mitochondria in Friedreich's Ataxia  
SCA7 fMRI  
miRNA SCA6  
ASO SCA3  
Friedreich's over time  
Chemical pathways in Friedreich's  
Pathways for polyQ regulation SCA3  
Microglia in SCA1  
Drugs for channels in SCA

#### POST-DOC FELLOWSHIP AWARDS

**Arancillo, Marife, Ph.D.**

Baylor College of Medicine, Houston, TX  
Neural Mechanisms of Cerebellar Function In Ataxia

**Bhalla, Angela, Ph.D.**

University of Alabama at Birmingham, AL  
Defining the role of mitochondrial DNA mutations in neuronal degeneration in Friedreich's ataxia

**Hernandez, Carlos R Castillo, Ph.D.**

Universidad Nacional Autonoma de Mexico  
Longitudinal study of neuropathology of spinocerebellar ataxia type 7 using fMRI

**Miyazaki, Yu, M.D., Ph.D.**

University of Chicago, IL  
Developing the novel microRNA-mediated therapeutic approach for spinocerebellar ataxia type 6.

**Rajpal, Gautam, Ph.D.**

University of Michigan, Ann Arbor, MI  
Antisense Oligonucleotide (ASO) treatment for Spinocerebellar Ataxia 3 (SCA3)

**Vannocci, Tommaso, Ph.D.**

King's College, London, England  
Understanding disease development in Friedreich's ataxia in a time-resolved way: a new cellular model

#### YOUNG INVESTIGATOR AWARD

**Donatello, Simona, Ph.D.**

Université Libre de Bruxelles, Brussels, Belgium  
The role of mTOR in Friedreich's ataxia and identification of new pathways for therapeutic intervention.

#### YOUNG INVESTIGATOR FOR SCA RESEARCH AWARDS

**Costa, Maria do Carmo Pereira, Ph.D.**

University of Michigan, Ann Arbor, MI  
Defining pathways that regulate levels of polyglutamine disease protein in MJD/SCA3

**Cvetanovic, Marija, Ph.D. (in Partnership with the Bob Allison Ataxia Research Center)**

University of Minnesota, Minneapolis, MN  
Role of Microglia in SCA1 pathogenesis

**Zhang, Miao, Ph.D.**

Chapman University School of Pharmacy, Irvine, CA  
Structural insights for drug discovery targeting SK2/3 channels for SCA

# NAF Grant Recipients in 2014

## PIONEER SCA TRANSLATIONAL RESEARCH AWARDS

Moving towards therapies

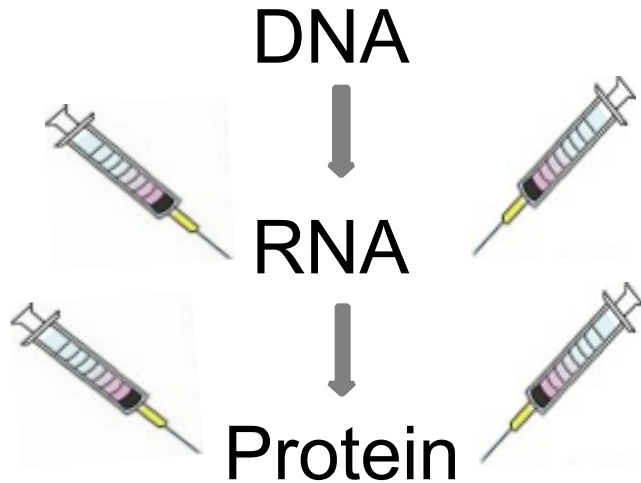

### **Al-Ramahi, Ismael, Ph.D.**

Baylor College of Medicine, Houston, TX

Identification of druggable targets that modulate the levels of SCA-causing proteins in vivo

### **Davidson, Beverly, Ph.D. (*in Partnership with the Bob Allison Ataxia Research Center*)**

Children's Hospital of Philadelphia, PA

Translating RNAi therapy for Spinocerebellar Ataxia 1 (SCA1) to the clinic

### **Ranum, Laura, Ph.D.**

University of Florida, Gainesville, FL

ASO targeting of bidirectional transcripts and RAN translation in SCA8

### **Schmidt, Thorsten, Ph.D.**

University of Tubingen, Tubingen, Germany

Targeting the intracellular localization of ataxin-3 as novel treatment strategy for Spinocerebellar Ataxia Type 3 (SCA3)

# *Genetics 101*

# *The DNA Double Helix*

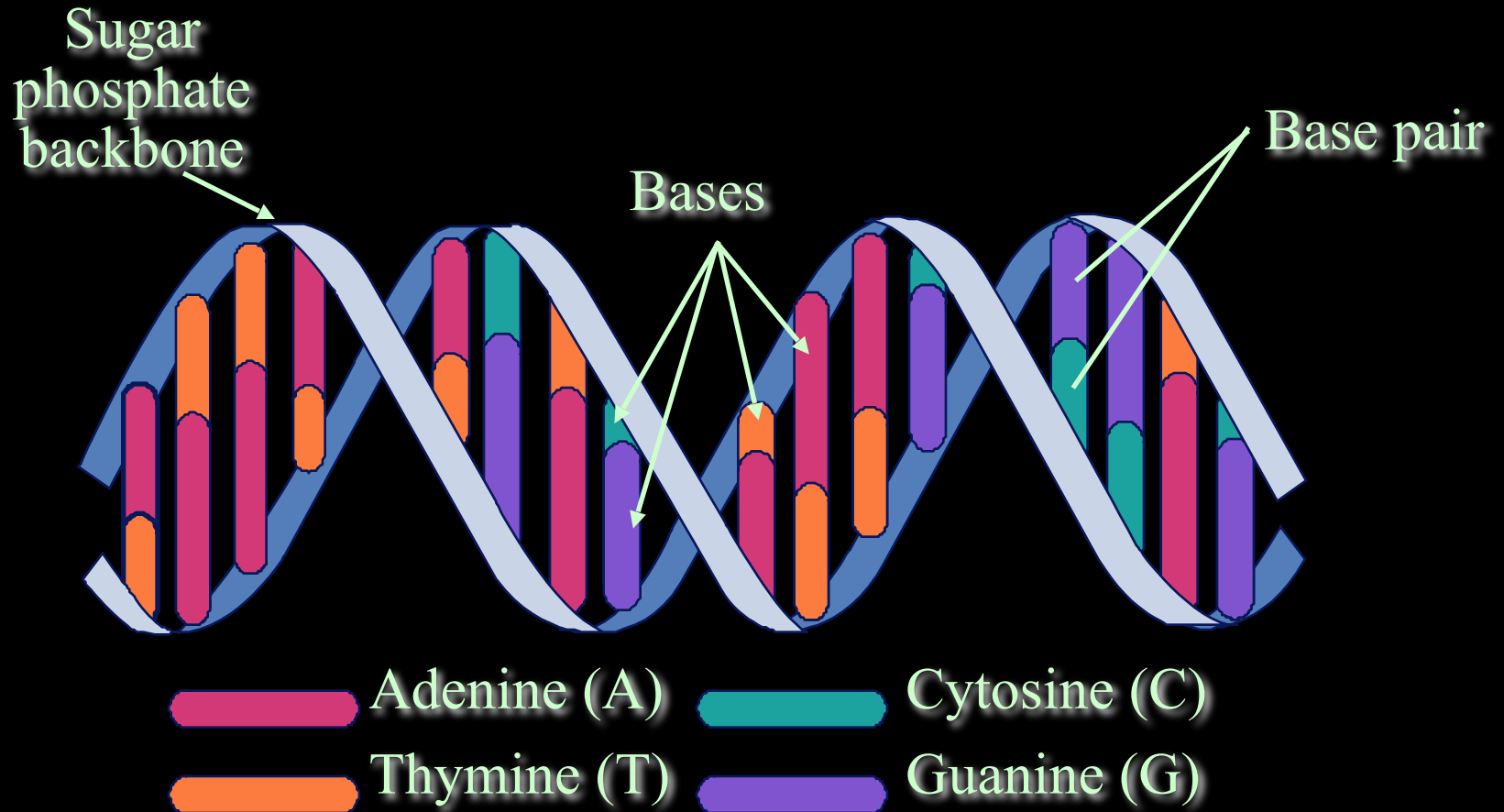

# Overview

## Chromosomes, DNA, Genes, Proteins

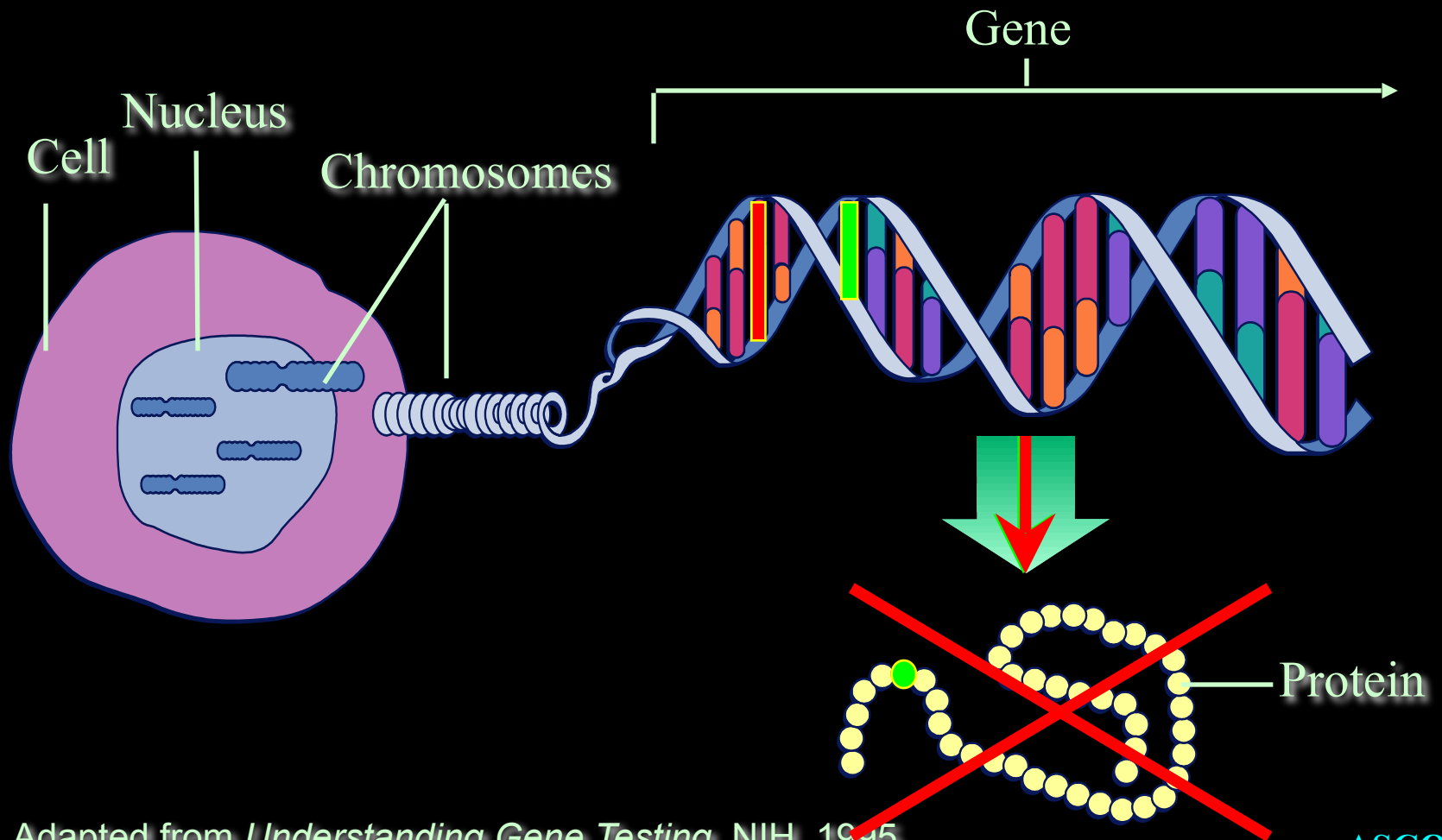

Adapted from *Understanding Gene Testing*, NIH, 1995

# *Central Dogma*

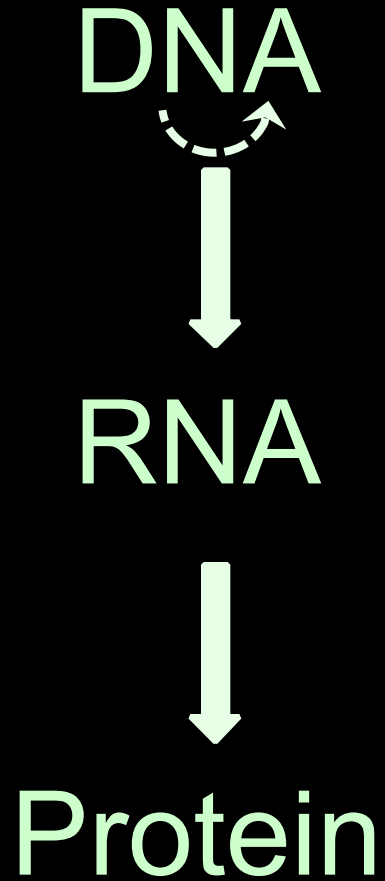

***GENOMIC SOFTWARE***  
***“The Code”***

***DNA → RNA CODONS → Protein***

Genomic DNA

THYBIGRYDDOGRANOUT

Messenger RNA

THEBIGREDDOGRANOUT

Translated Message

THE BIG RED DOG RAN OUT

# *Organization of a Gene*

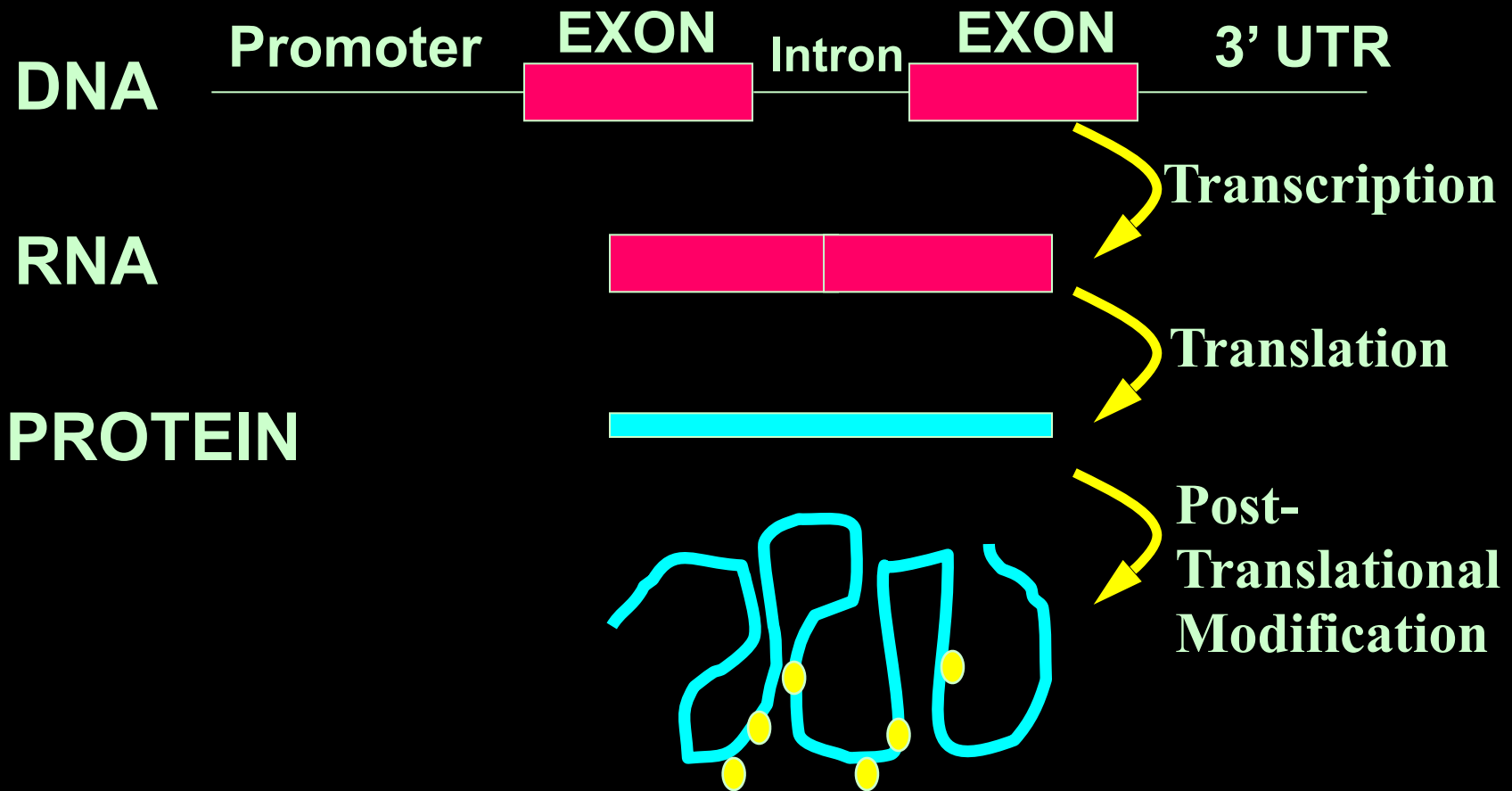

# *Genetics of Disease*

# *Disease-Associated Mutations*

A mutation is a change in the normal base pair sequence

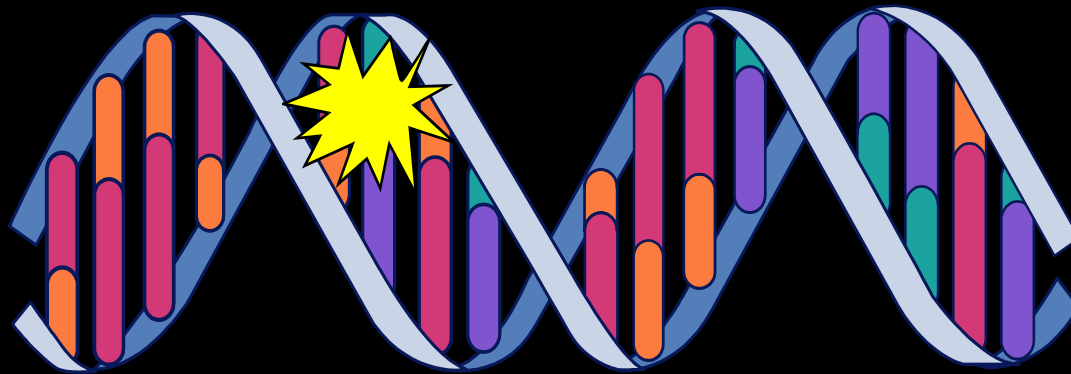

Commonly used to define DNA sequence changes that alter protein function

# *Disease-Associated Mutations Can Alter Protein Function*

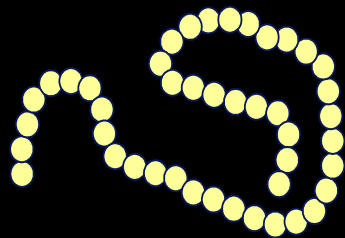
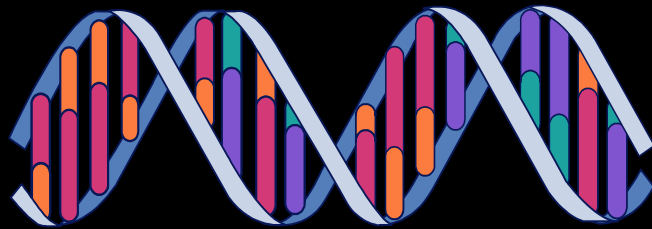

Functional protein

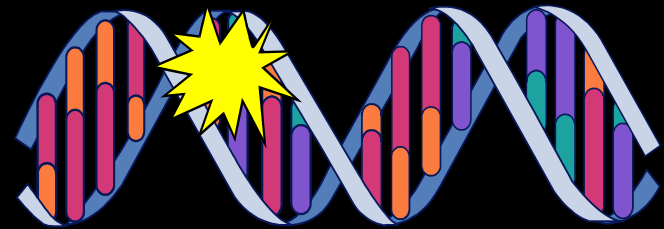

Nonfunctional or  
missing protein

# *Point Mutations*

Normal THE BIG RED DOG RAN OUT.

Missense THE BIG RAD DOG RAN OUT.

Nonsense THE BIG RED.

Frameshift (deletion) THE BRE DDO GRA.

Frameshift  
(insertion) THE BIG RED ZDO GRA.

Point mutation: a change in a single base pair

# Autosomal Dominant Inheritance

- Each child has 50% chance of inheriting the mutation
- Equally transmitted by men and women

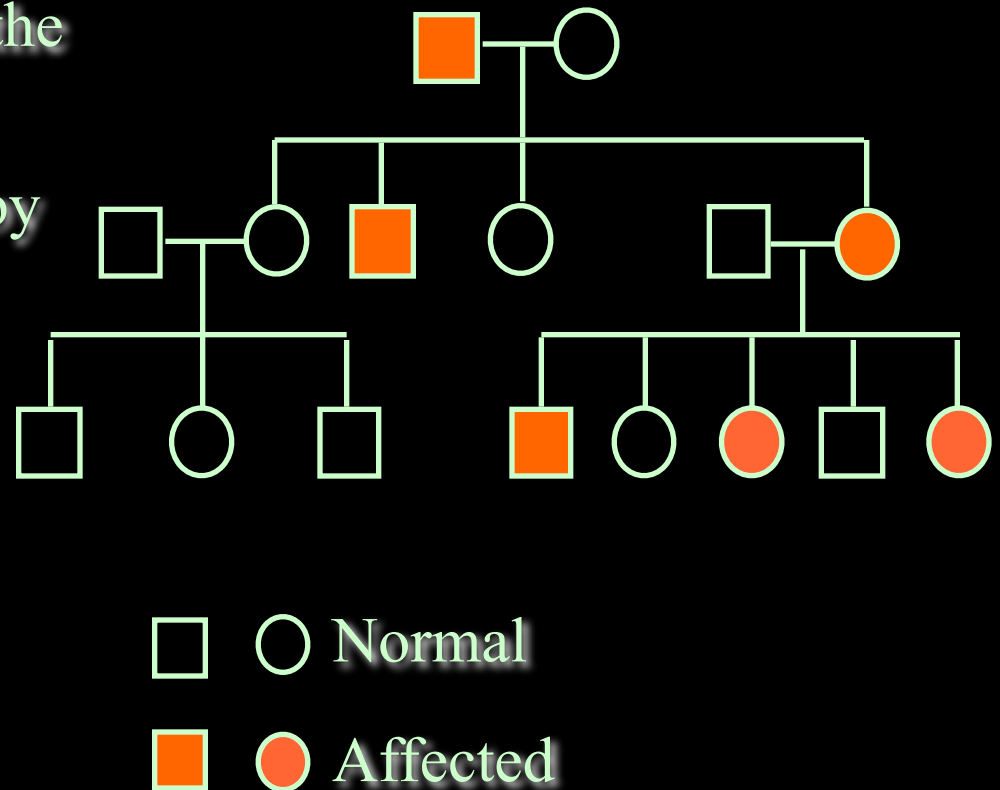

# Autosomal Recessive Inheritance

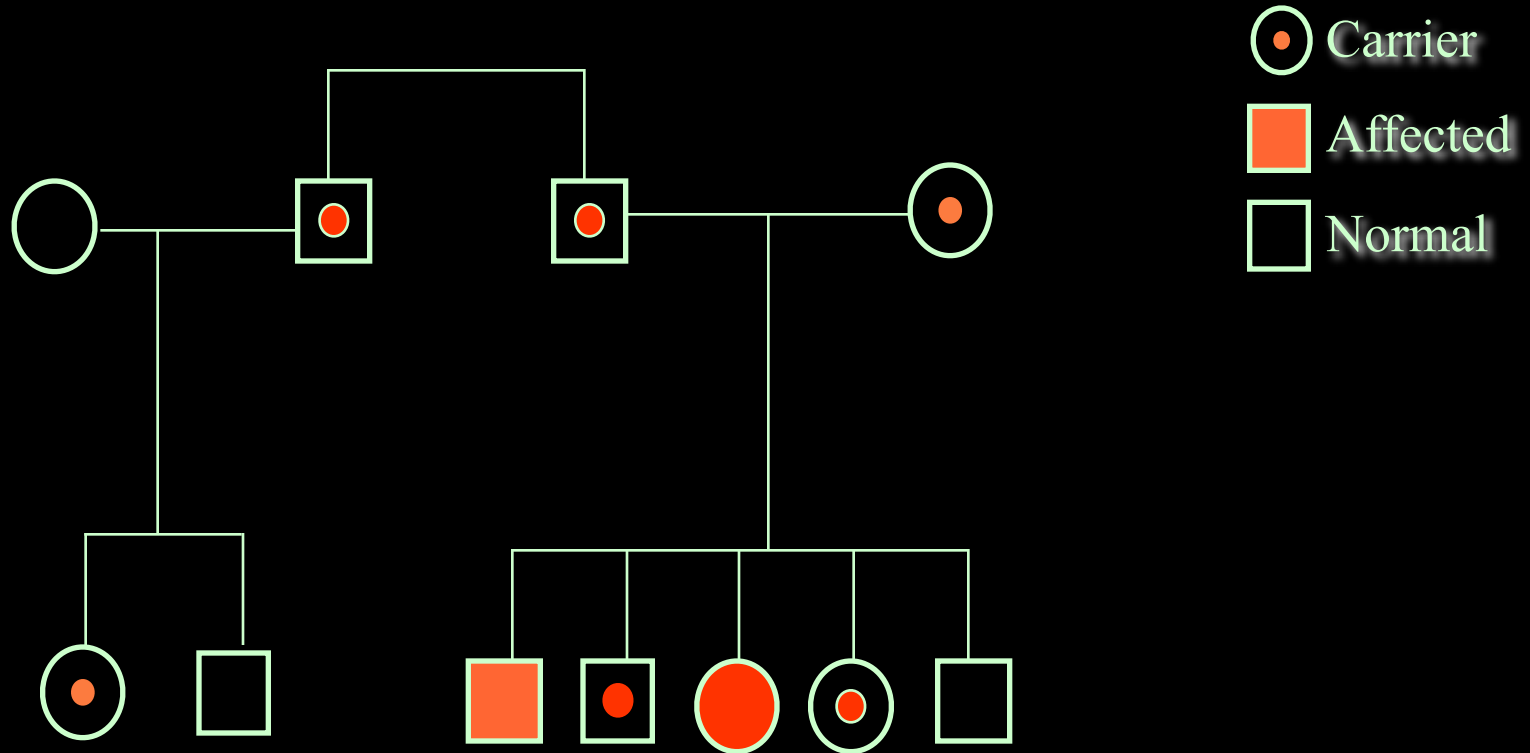

# *Drinking from a hydrant*



*Genetics 101* → *2015*

# Positional cloning overview

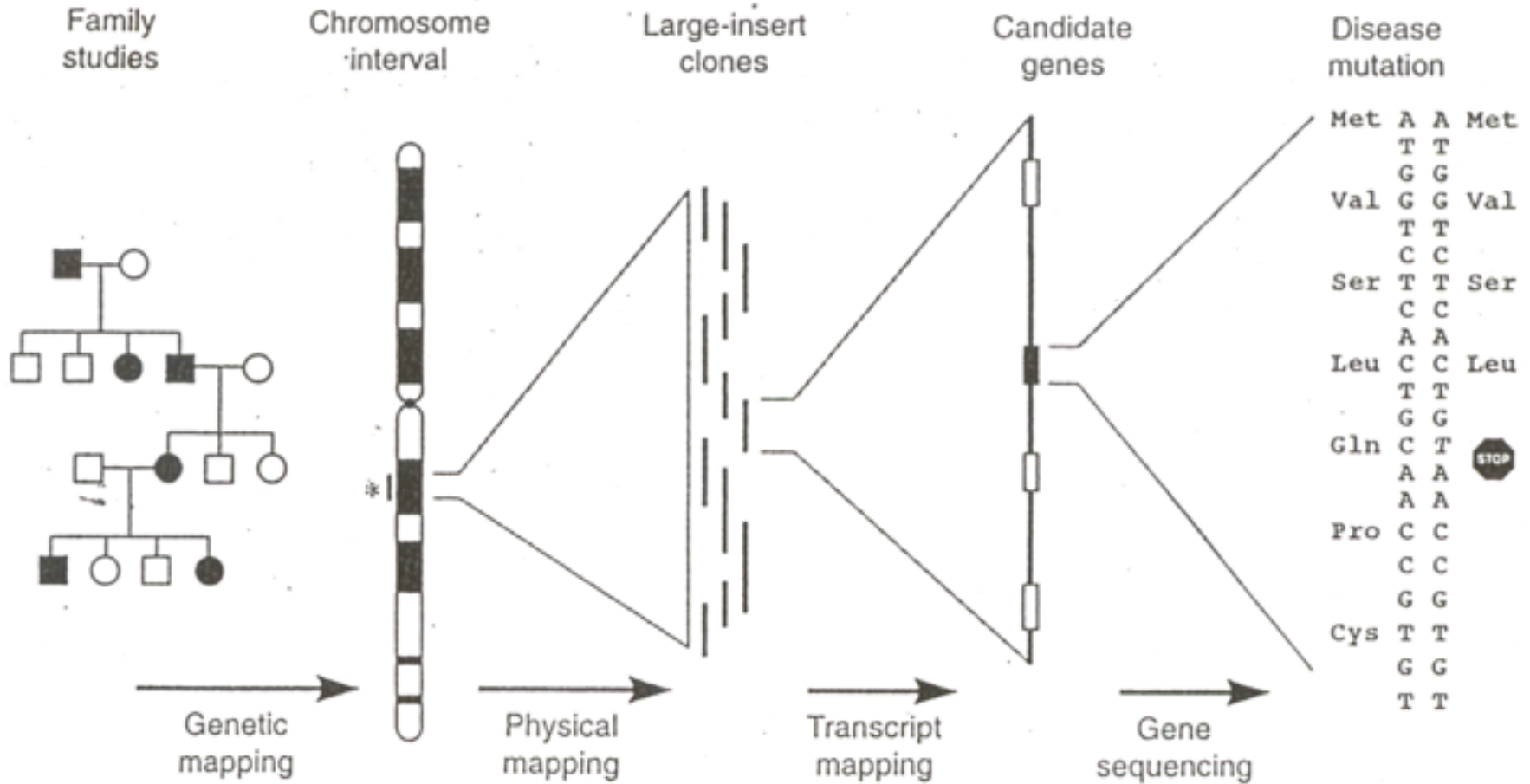

*Disease mutations can be repeat  
expansions 1990s*

# SCA1 Gene – Repeat Length Changes Protein

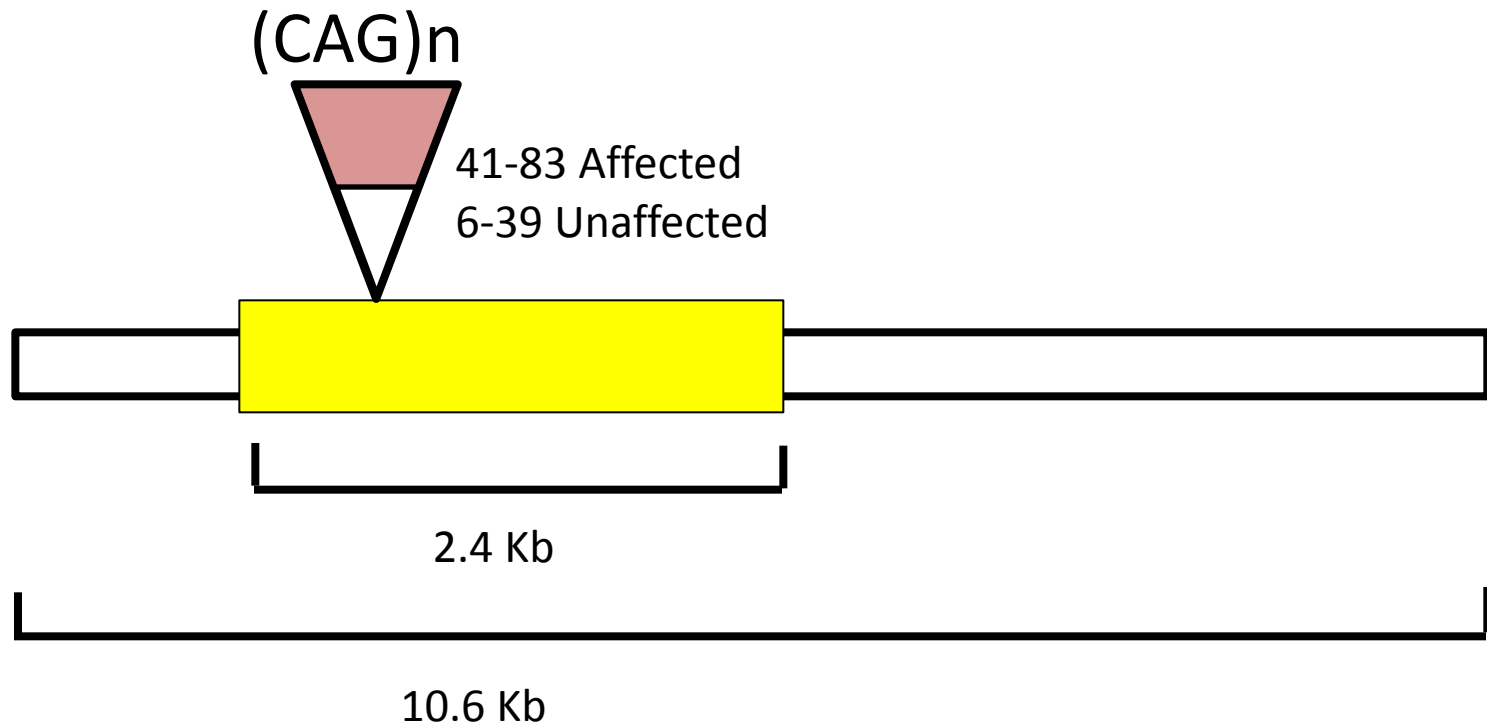

# Polyglutamine Protein Aggregates in Patient Cells Cause Cellular Problems.

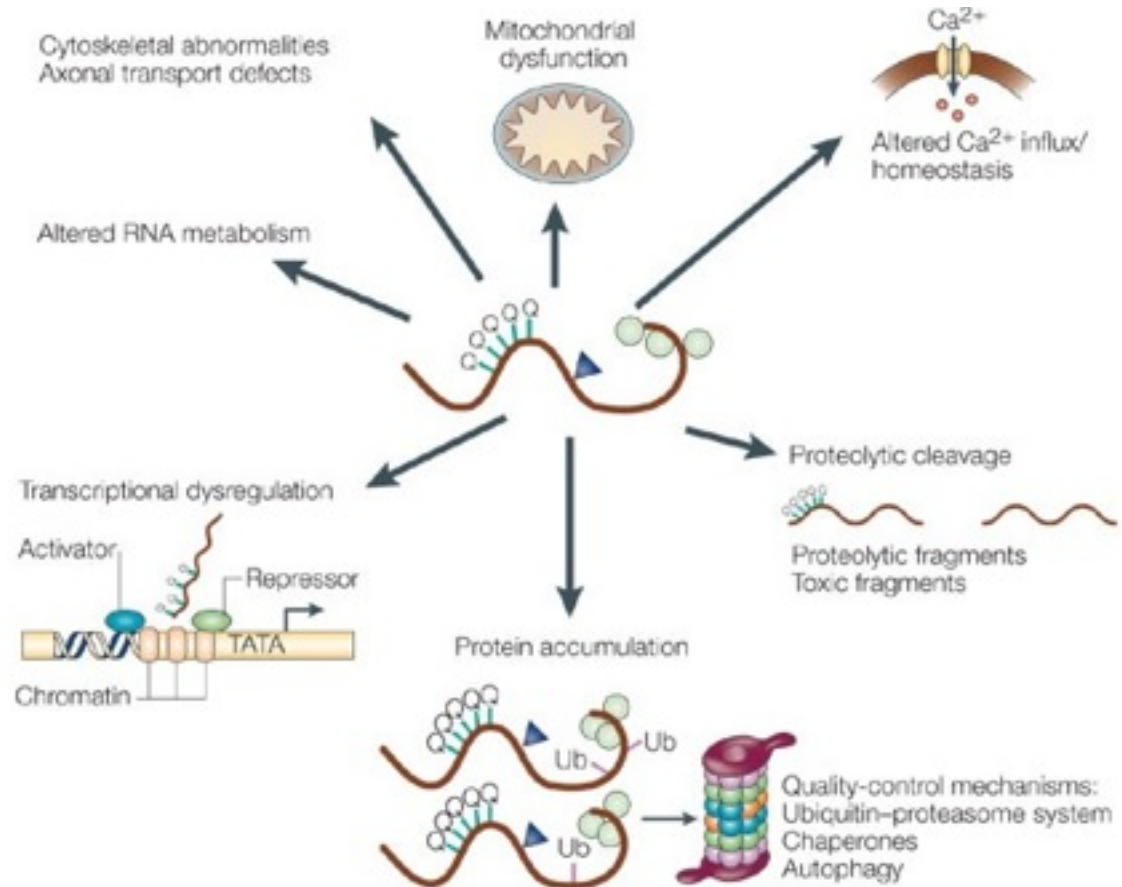
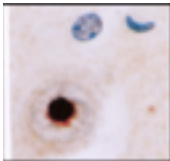

Copyright © 2005 Nature Publishing Group  
**Nature Reviews | Genetics**

*Modified from Gatchel & Zoghbi, Nature Reviews Genetics, 2005*

# Purkinje Cell Degeneration

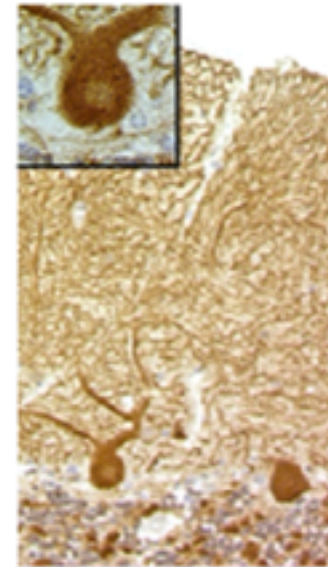
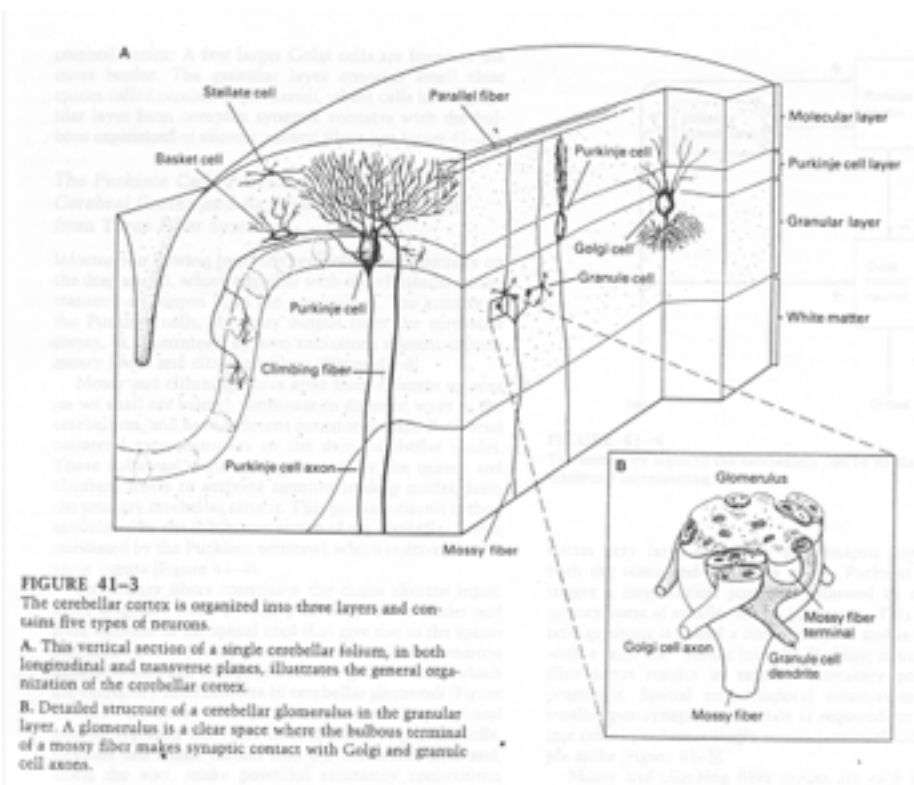

Control

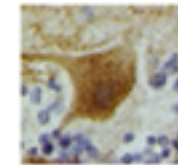

Ataxia

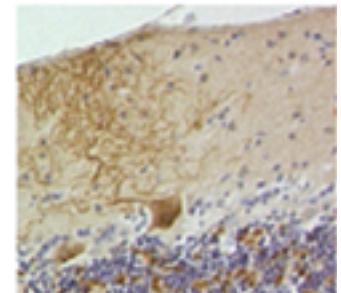

*Ikeda et al., Nat Genet. 2006;38:184-90*

Purkinje cells degenerate in most ataxias

# Clinical Features of Ataxia

- Limb and gait incoordination
- Eye movement abnormalities
- Slurred speech
- Babinski signs
- Rapidly or slowly progressive
- Cerebellar/brain stem atrophy

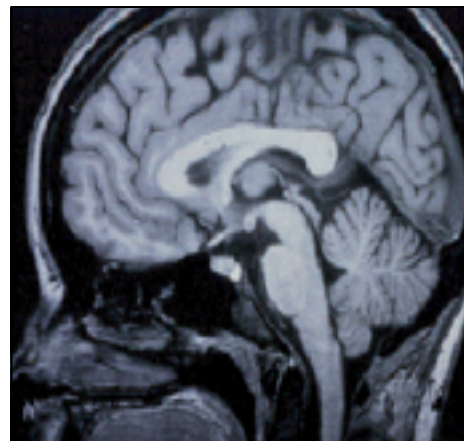

Control

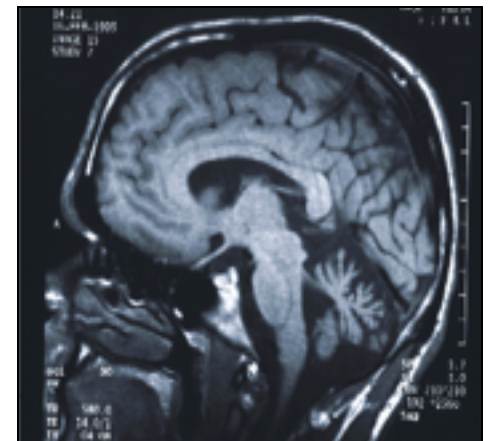

Affected

## Experimental “models” for myotonic dystrophy

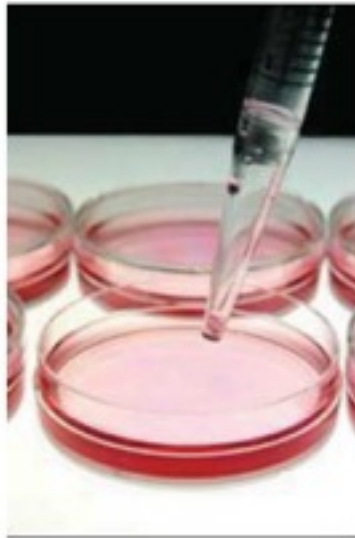

# RNA interference (RNAi)

“Shooting the messenger”

Mutant Gene



m~~RNA~~



“Toxic” Protein



Brain Dysfunction

**Davidson, Beverly, Ph.D. (*in Partnership with the Bob Allison Ataxia Research Center*)**

Children's Hospital of Philadelphia, PA  
Translating RNAi therapy for  
Spinocerebellar Ataxia 1 (SCA1) to the  
clinic

# Reduce mutant protein

Mutant Gene



mRNA



“Toxic”~~X~~Protein



Brain Dysfunction

**Al-Ramahi, Ismael, Ph.D.**

Baylor College of Medicine, Houston, TX  
Identification of druggable targets that modulate the levels of SCA-causing proteins in vivo

**Schmidt, Thorsten, Ph.D.**

University of Tübingen, Tübingen, Germany  
Targeting the intracellular localization of ataxin-3 as novel treatment strategy for Spinocerebellar Ataxia Type 3 (SCA3)





# DNA → RNA CODONS → Protein

Genomic DNA

THYBIGRYDDOGRANOUT

Messenger RNA

THEBIGREDDOGRANOUT

Translated Message

THE BIG RED DOG RAN OUT



The code is read three letters at a time and the ATG sets the reading frame

# Protein coding and non-coding expansion disorders ~2005

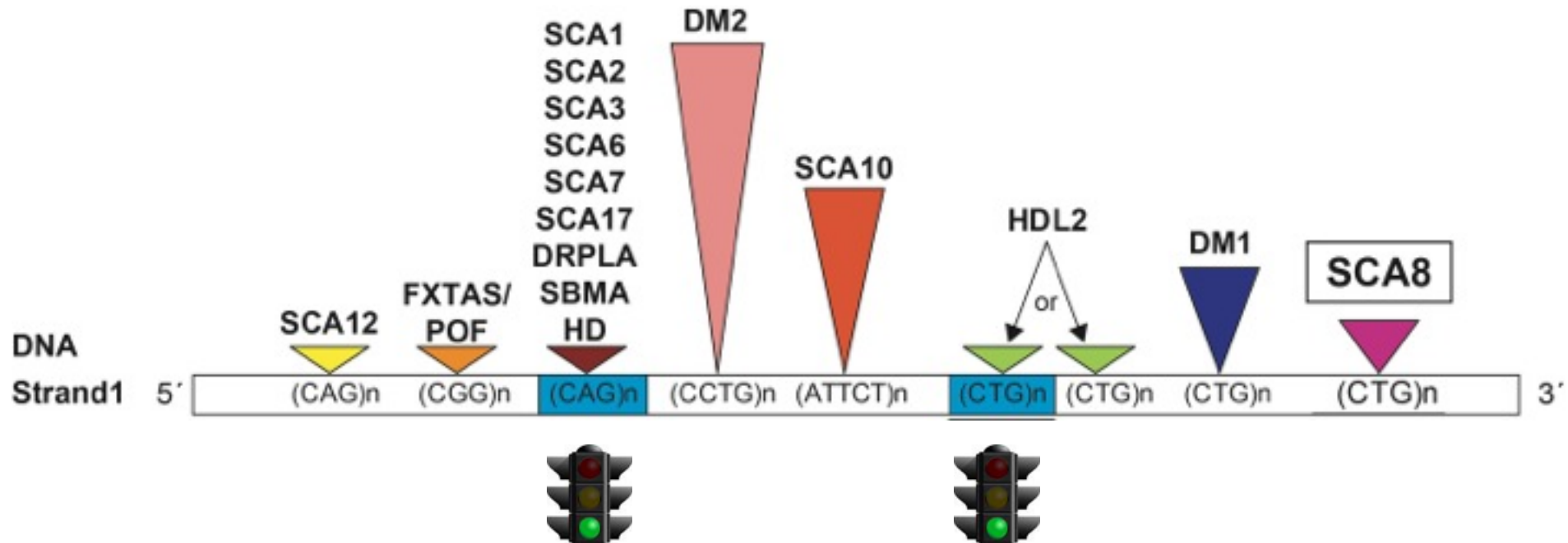

*Spinocerebellar Ataxia Type 8*  
*SCA8*

# SCA8 transgenic mice

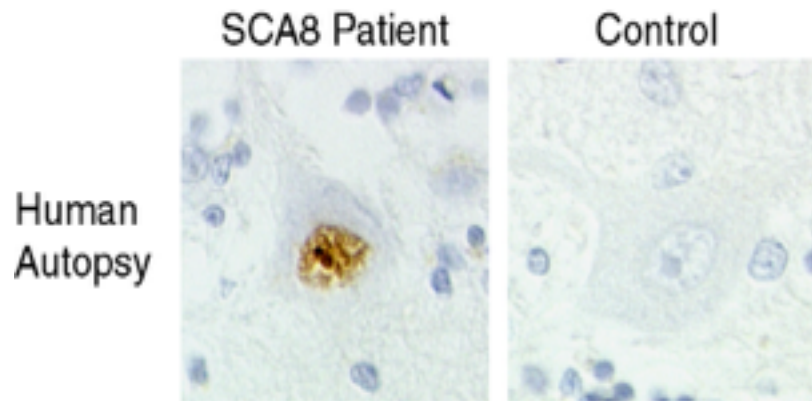
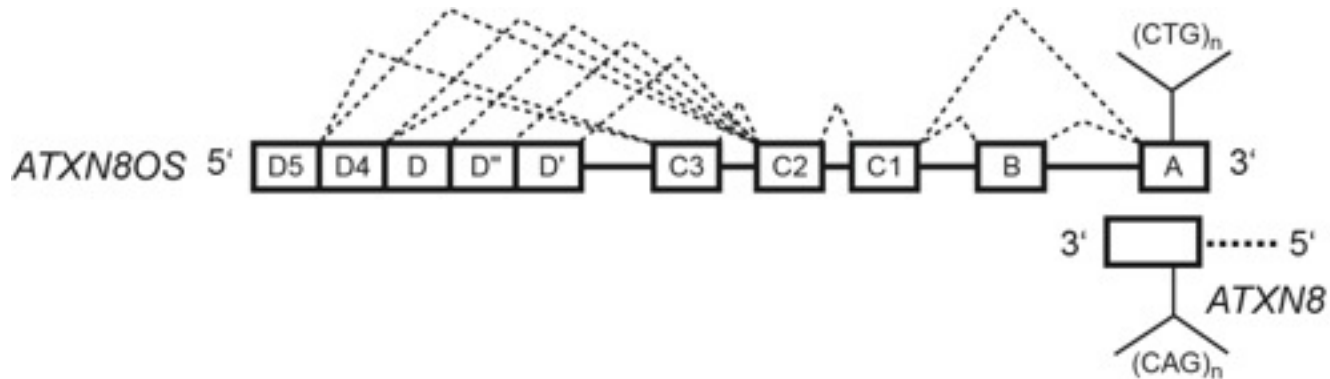

Nuclear polyGln inclusions in humans and mice detected with 1C2 antibody

# SCA8: one mutation two genes

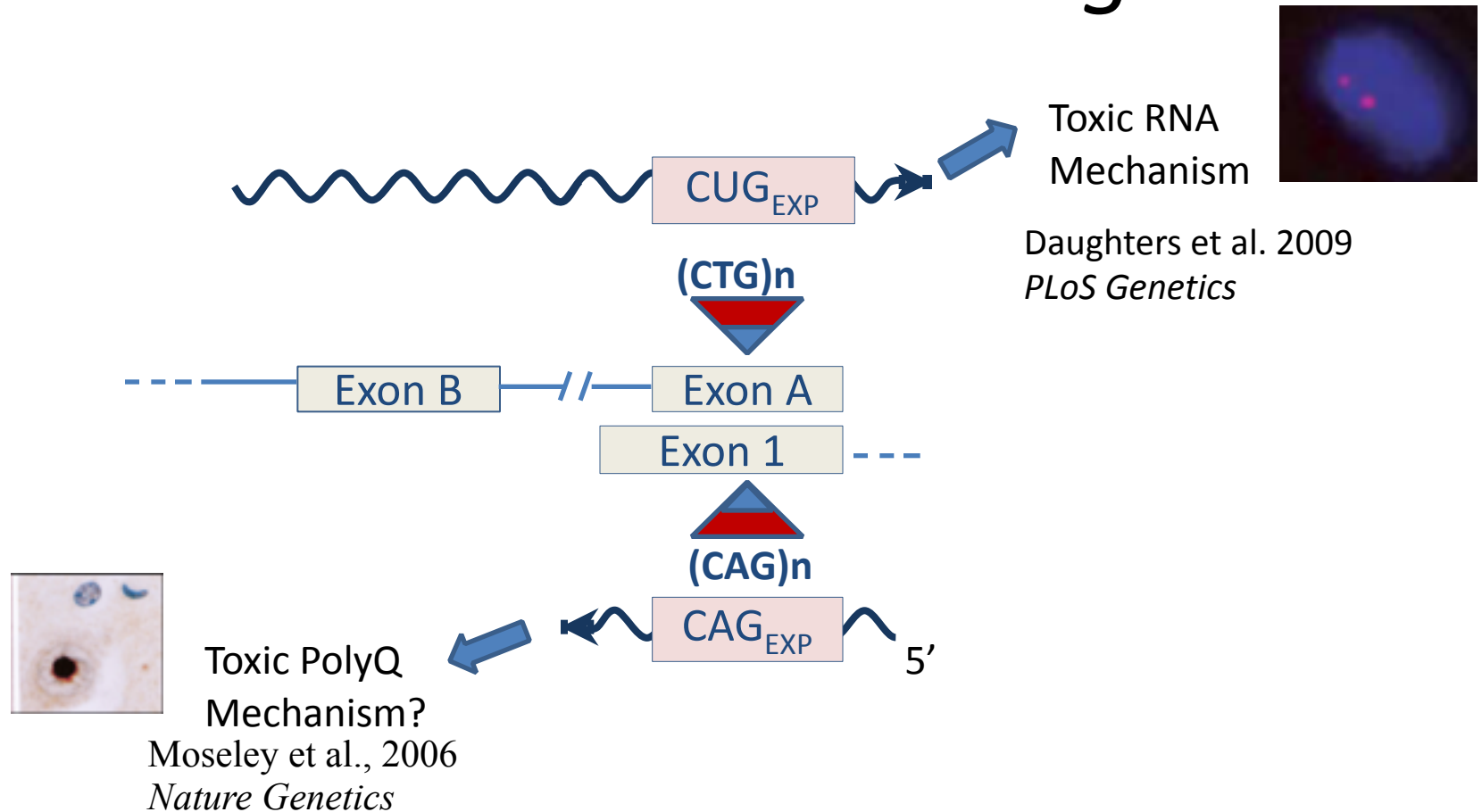

5' TAAAAA**ATG**(CAG)<sub>103</sub>CGG(CAG)<sub>7</sub>CGG(CAG)<sub>5</sub>TAGTAGTAGTAAACG

\* **M(Q)**<sub>103</sub>**R(Q)**<sub>7</sub>**R(Q)**<sub>5</sub>\*\*\*\*

# Discovery of Repeat-Associated Non-ATG Translation (RAN translation)

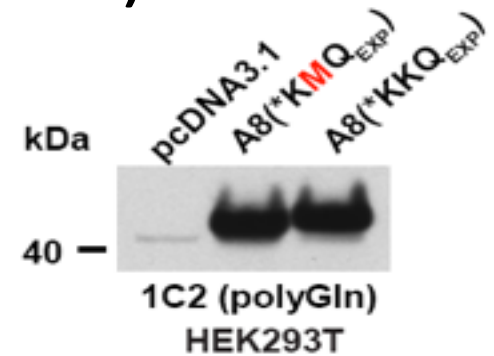
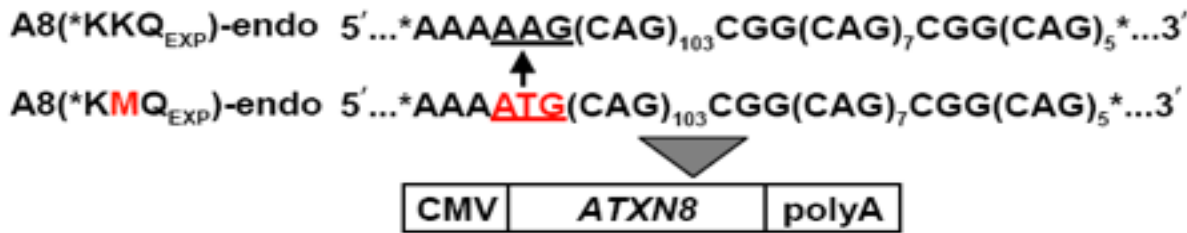

Frame	Codon	Amino Acid
1	CAG	Glutamine(Q)
2	AGC	Serine(S)
3	GCA	Alanine(A)

CAGCAGCAGCAGCAGCAGCAGCAG

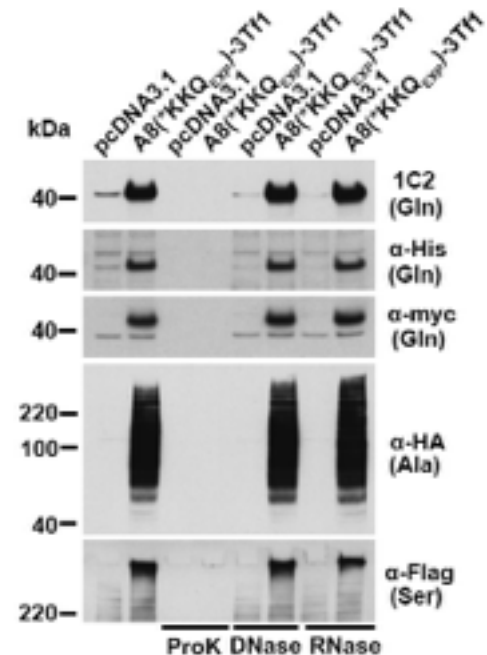

# DNA → RNA → Protein

Genomic DNA

THYBIGRYDDOGRANOUT

Messenger RNA

THEBIGREDDOGRANOUT

Translated Message



THE BIG RED DOG RAN OUT



HEB IGR EDD OGR ANO UTT



EBI GRE DDO GRA NOU TTH

Repeat Associated Non-ATG (RAN) translation

# *RAN Translation in vivo: SCA8*

$\alpha$ -SCA8 poly-GCA-Ala

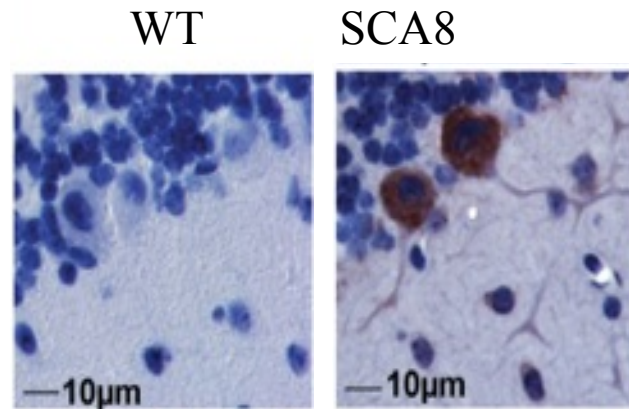

Mouse Cerebellum

$\alpha$ -DM1 poly-CAG-Gln

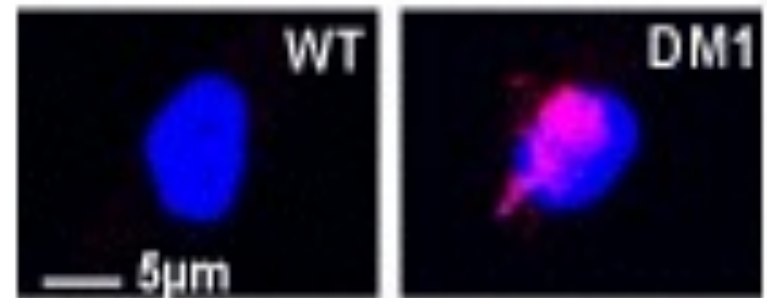

Human Myoblasts

# SCA8: one mutation two genes up to six proteins

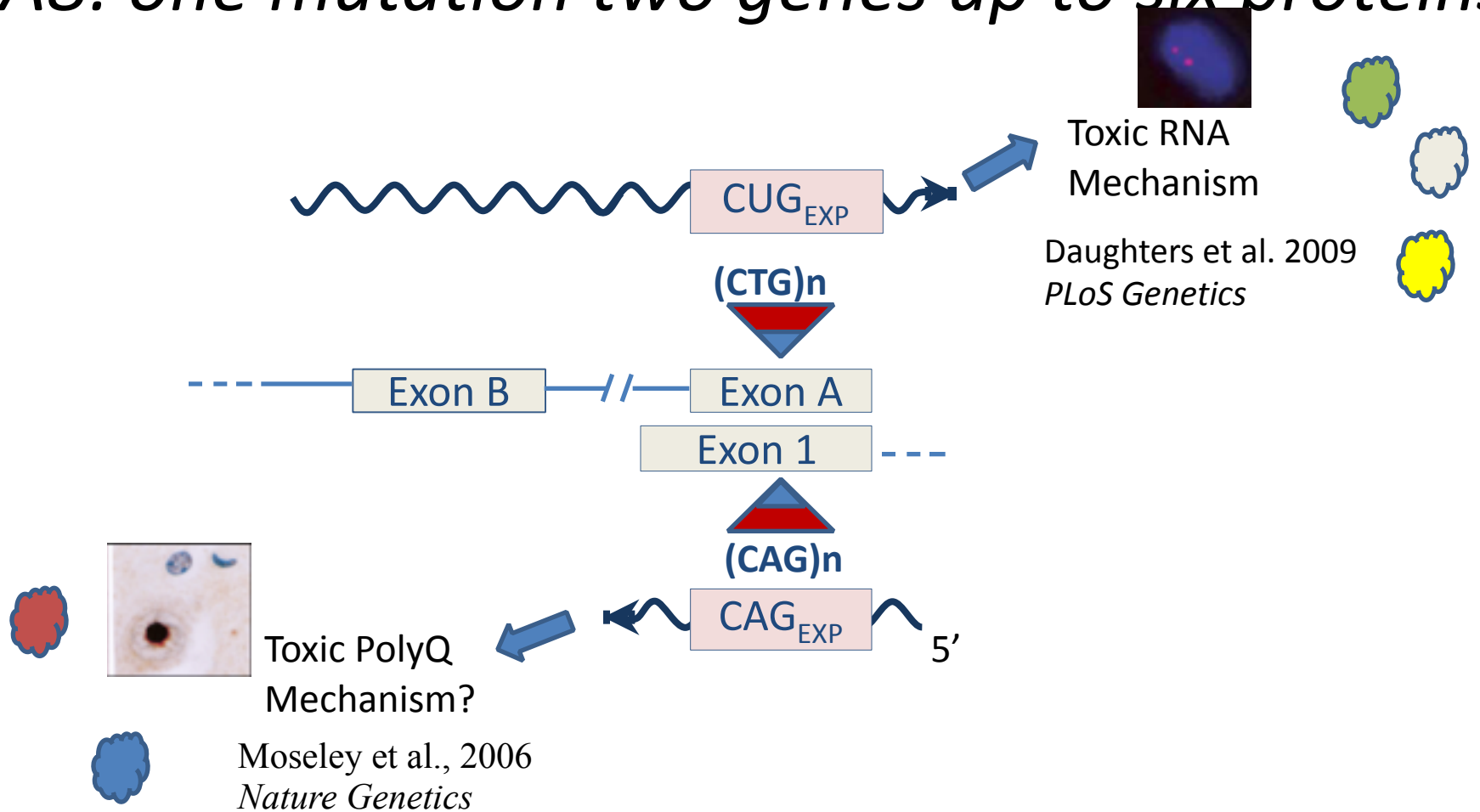

## Targeted degradation of toxic RNA by gapmer ASOs

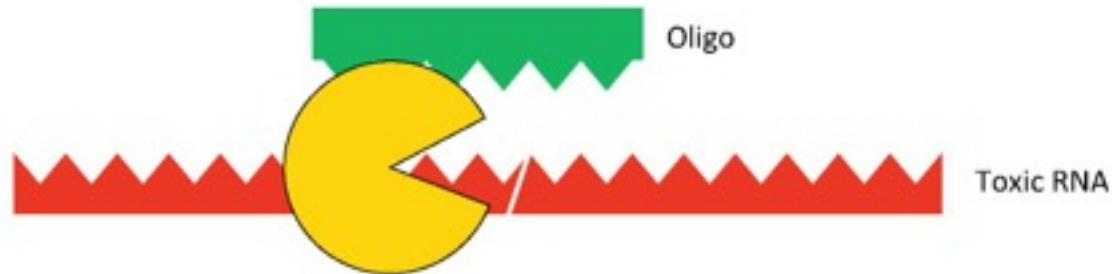

# Target both RNAs

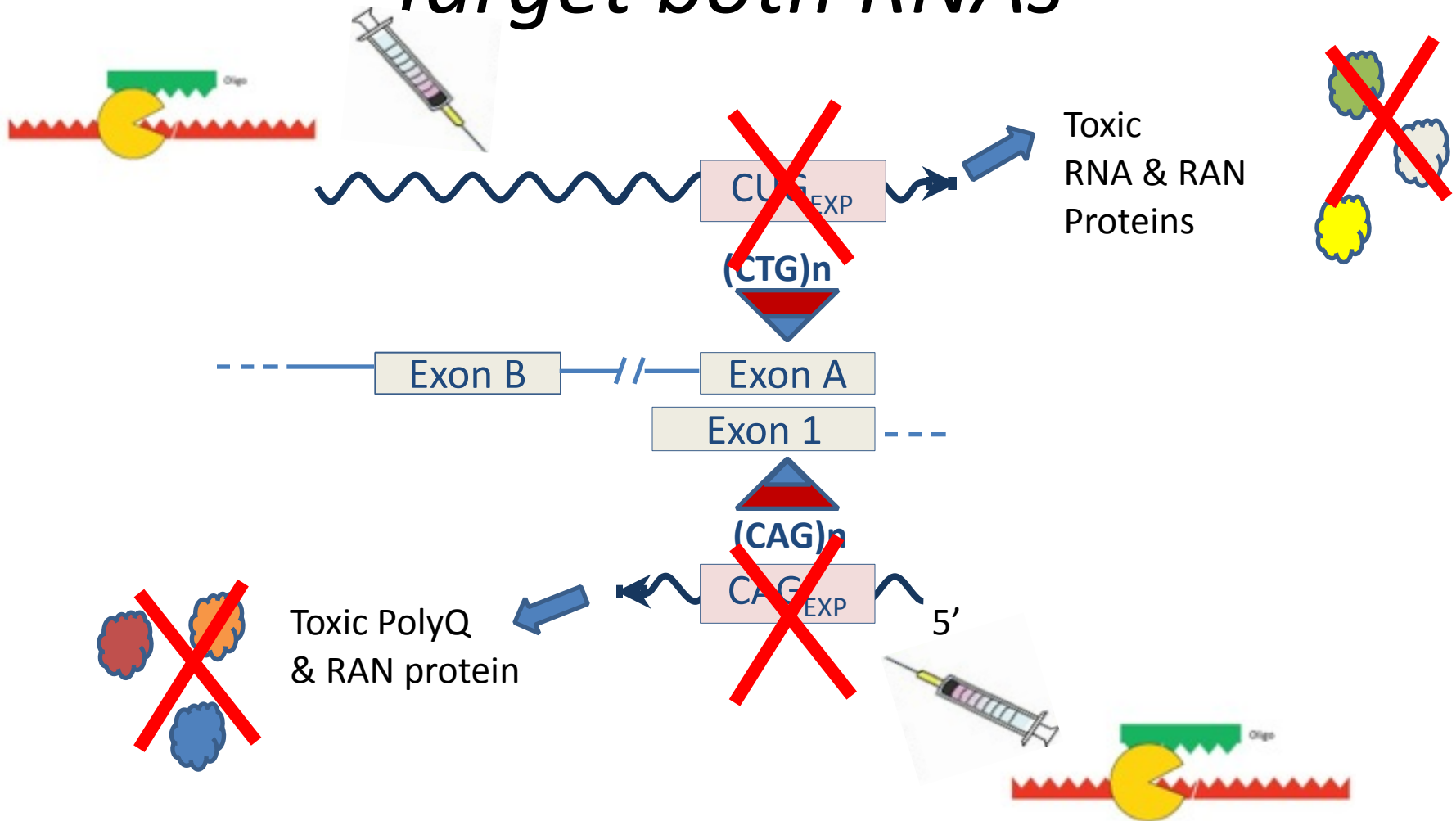

# New view of expansion disorders

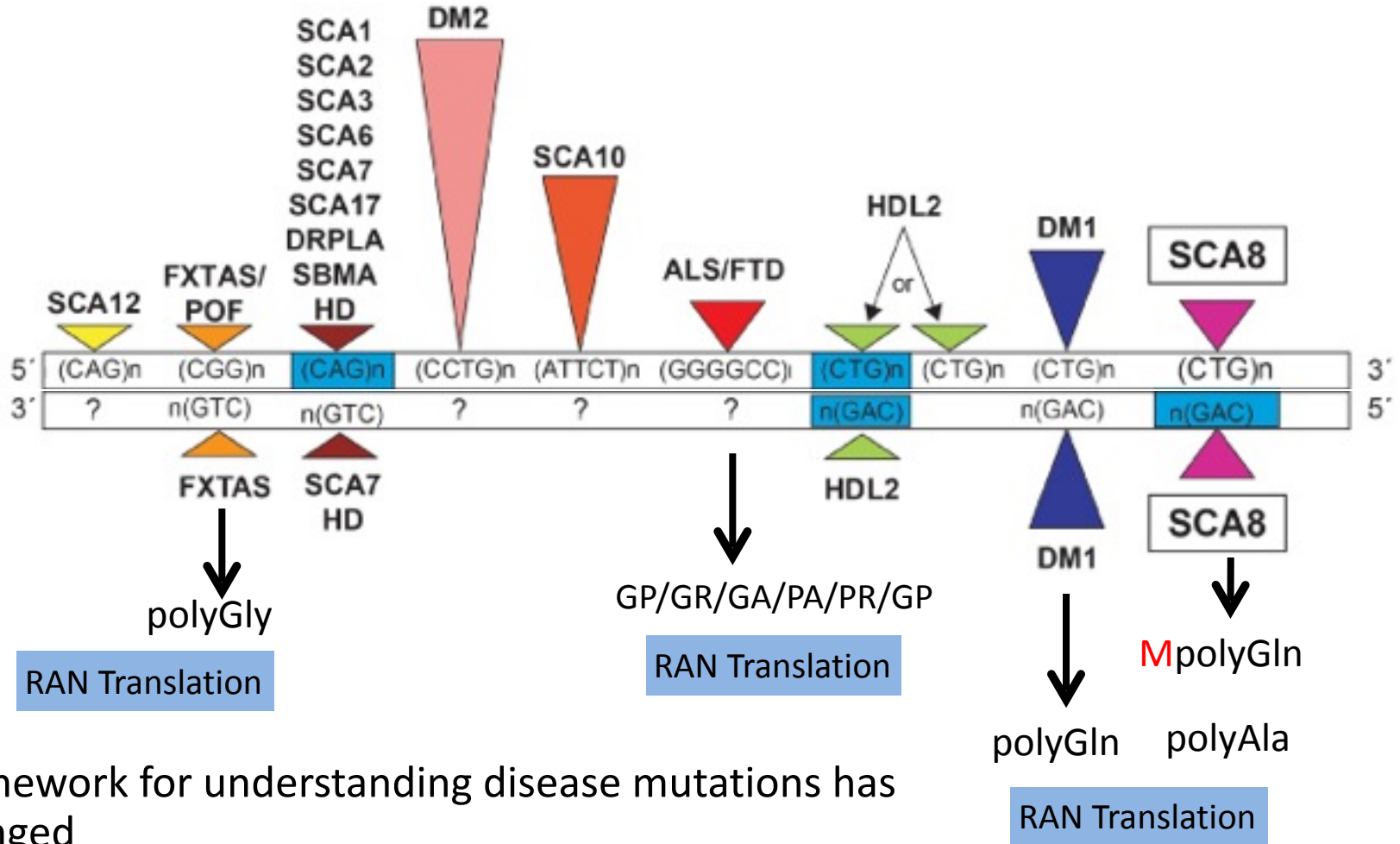

Framework for understanding disease mutations has changed

- Bidirectional expression is common
- Repeats express unexpected proteins
- Impact on strategies to treat these diseases

# *Conclusions*

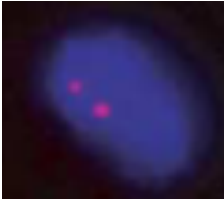

# THANK YOU!!!!!!



- NAF funding critically important for understanding the causes of ataxia and developing treatments
- Therapeutic efforts to target RNA and protein pathways are underway.
- Lessons from one disease connect to other diseases

# Acknowledgements

## University of Florida

### Ranum Lab

- **Tao Zu**
- **Yuanjing Liu**
- **John Cleary**
- **Monica Bañez Coronel**
- **Tammy Reid**
- Fatma Ayhan
- David Deal
- Amrutha Pattamatta
- Barbara Perez
- Alex Tarabochia
- Solaleh Tusi

## University of Minnesota

- Tim Ebner
- Brent Clark
- Mathew Stone
- Todd Markowski
- Stephen Schmechel
- Nik Somia
- Walter Low
- Peter Bitterman
- Mark Peterson

## INSERM France

- Genevieve Gourdon
- Mario Gomes-Pereira
- Aline Huguet

## University of Florida

- **Maurice Swanson**
- Tetsuo Ashizawa
- S.H. Subramony
- Anthony Yachnis

## Johns Hopkins

- **Jeffrey Rothstein**
- **Juan Troncoso**
- Lyle Ostrow

## Washington University

- Tim Miller



The Marigold Foundation  
Creating Hope & Opportunity



# THANK YOU



# *Discoveries of how genes work in SCA8*

- Story about an Elephant:

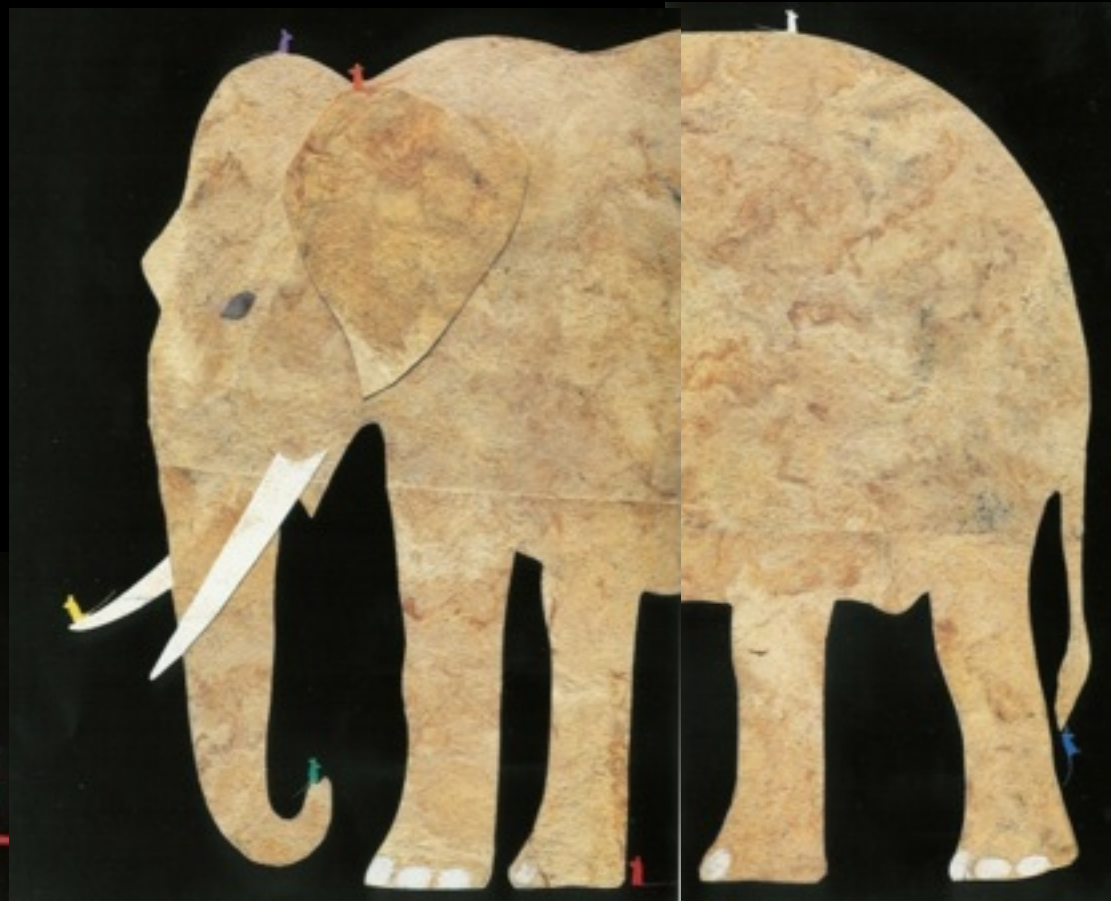

**Ed Young: Seven Blind Mice**

# Microsatellite Expansion Diseases

Fragile X Syndrome

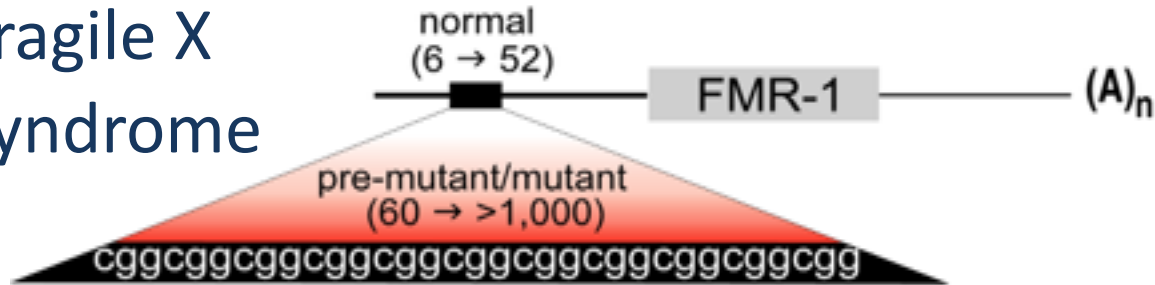

**Protein Loss**

Huntington Disease

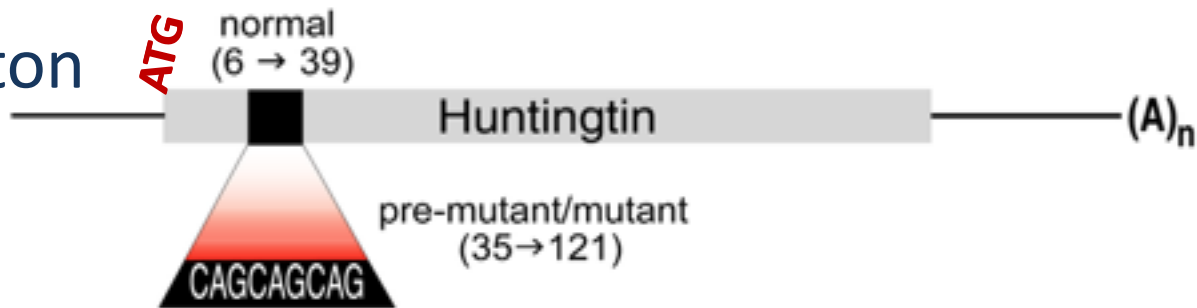

**Protein Gain**

Myotonic Dystrophy

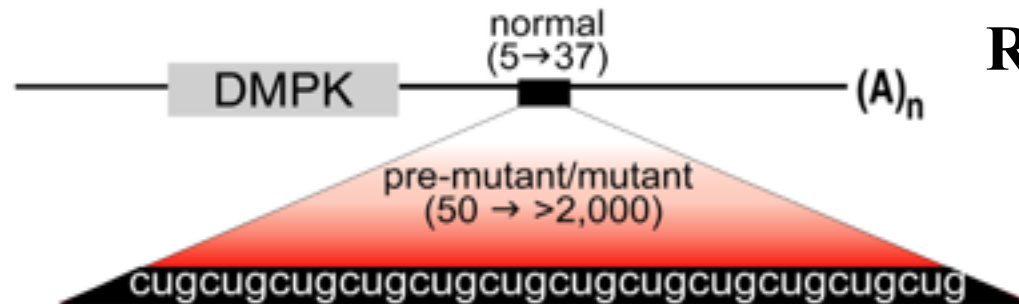

**RNA Gain**

# Protein coding and non-coding expansion disorders ~2005

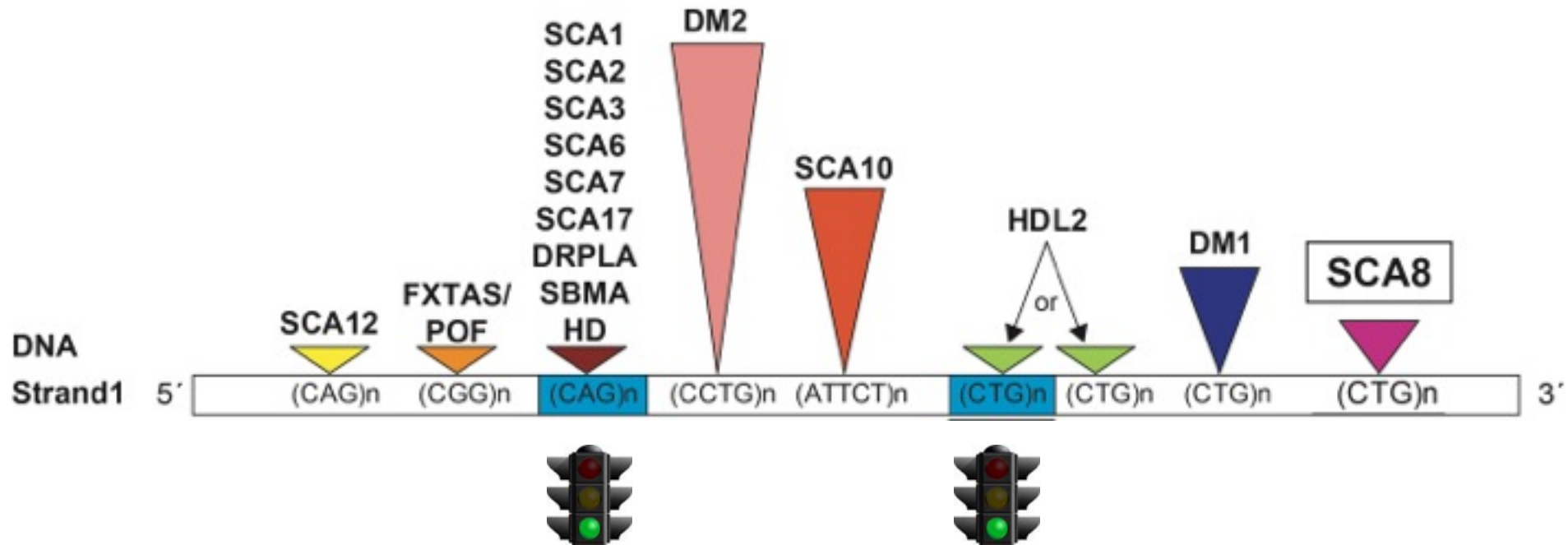

# DNA → RNA CODONS → Protein

Genomic DNA

THYBIGRYD(RYD)<sub>60</sub>DOGRANOUT

Messenger RNA

THEBIGRED(RED)<sub>60</sub>DOGRANOUT

Translated Message

THE BIG RED (RED)<sub>60</sub> DOG RAN OUT



The code is read three letters at a time and the ATG sets the reading frame

## Targeted degradation of toxic RNA by gapmer ASOs

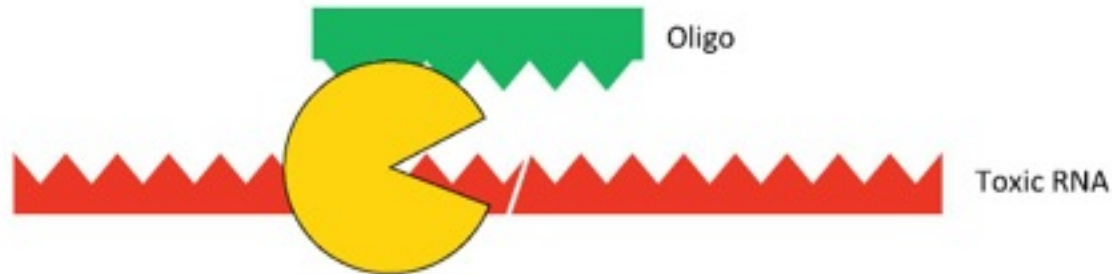



## Myotonic dystrophy, type 2 (DM2)

