

A vibrant, abstract background featuring a variety of tropical leaves in shades of yellow, orange, and blue. The leaves are stylized with patterns of dots and stripes. A dark gray rectangular box is centered on the right side of the image, containing the title and author information.

# Genetic Counseling

Jennifer Pagano  
MSc Candidate, Genetic Counseling Training Program  
University School of Medicine

# What is Genetic Counseling?

Genetic counseling is the process of helping people understand and adapt to the medical, psychological, and familial implications of genetic contributions to disease.

This process integrates:

- Interpretation of family and medical histories to assess the chance of disease occurrence or recurrence.
- Education about inheritance, testing, management, prevention, resources, and research.
- Counseling to promote informed choices and adaptation to the risk or condition.

*National Society of Genetic Counselors, 2005*

# What is Genetic Counseling?

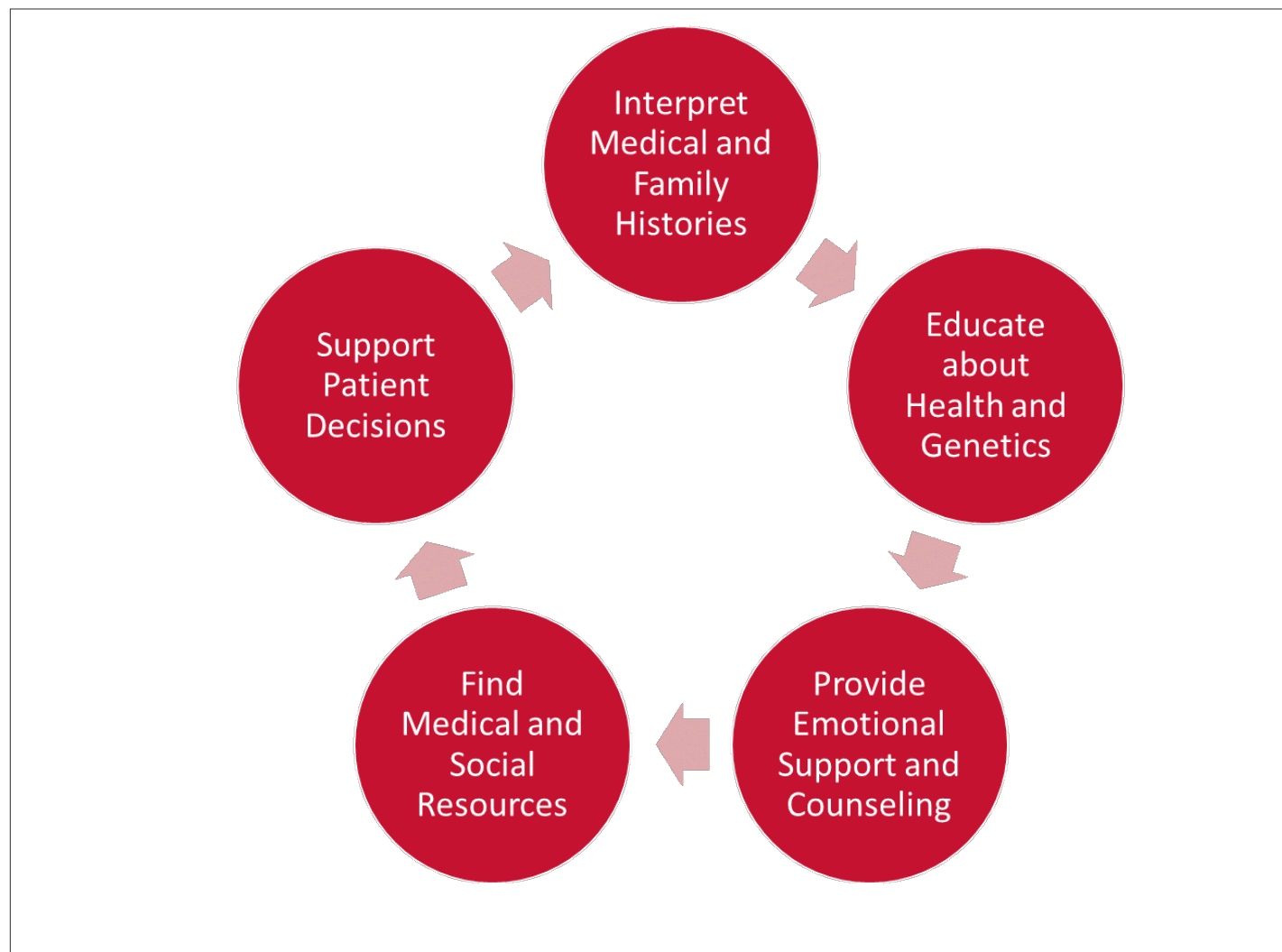

# Scientific Advances

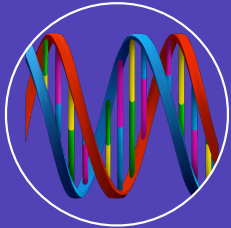

DNA helix  
1953



46  
chromosomes  
1956

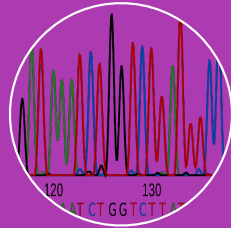

DNA  
sequencing  
1977



First draft of  
Human  
Genome 2001



Next  
generation  
sequencing  
2015



## Who are Genetic Counselors in 2020?

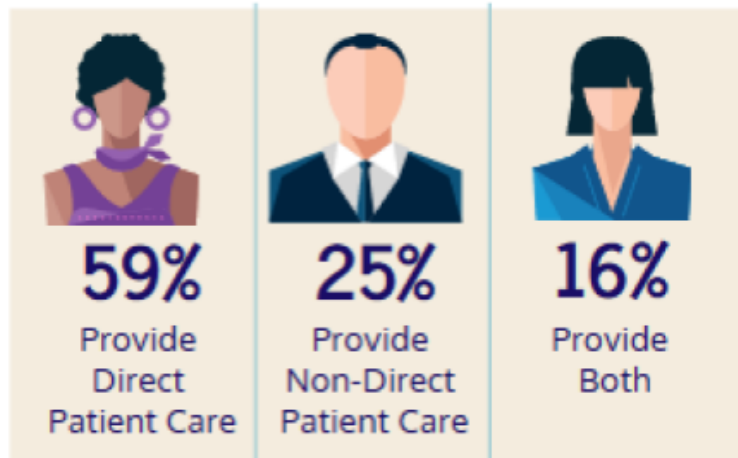

- Specialized healthcare professionals
  - Master's Degree in Genetic Counseling
  - Must be certified by ABGC
- Experts in genetics AND communication
- Patient advocates
- Educators
- Researchers
- Administrators



Genetic Counseling is a unique and specialized STEM (Science, Technology, Engineering and Math) career



9 of 10 genetic counselors reported being satisfied with their job

Genetic counselors are passionate about helping patients and medical professionals use genetic information to make decisions



The U.S. Bureau of Labor Statistics projects a growth rate of 29% for GC jobs through 2026, much faster than other occupations

# Career Profile

*NSGC Professional Status Survey 2018*

# History of the Profession

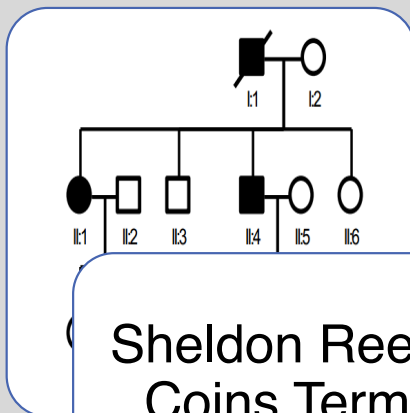

Sheldon Reed  
Coins Term  
Genetic  
Counseling in  
1947



First GC  
Program at  
Sarah  
Lawrence in  
1969



49 Accredited  
Programs in  
2019



## Practice Areas & Settings

- Hospitals and clinics
- Public health
- Universities
- Government
- Insurance companies
- Non-profits
- Private GC companies
- Pharmaceutical companies
- Clinical genetic laboratories

# Prenatal Counseling

- Work with women and families who are already pregnant or considering having a child
- May have an increased risk of birth defect or genetic condition
- Explain standard prenatal testing
- Carrier Screening
- Reproductive Assistive Technology
- Teratology



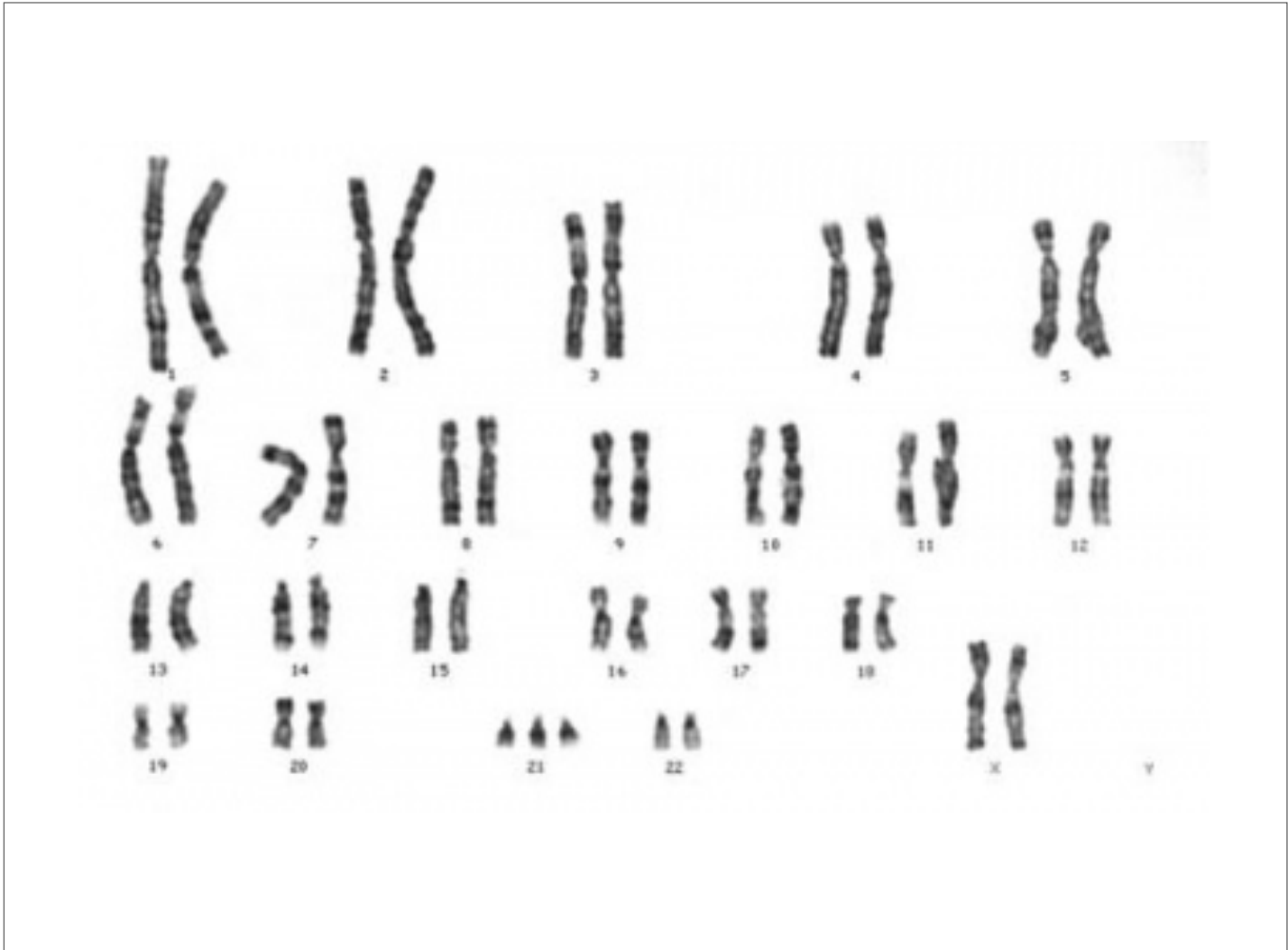

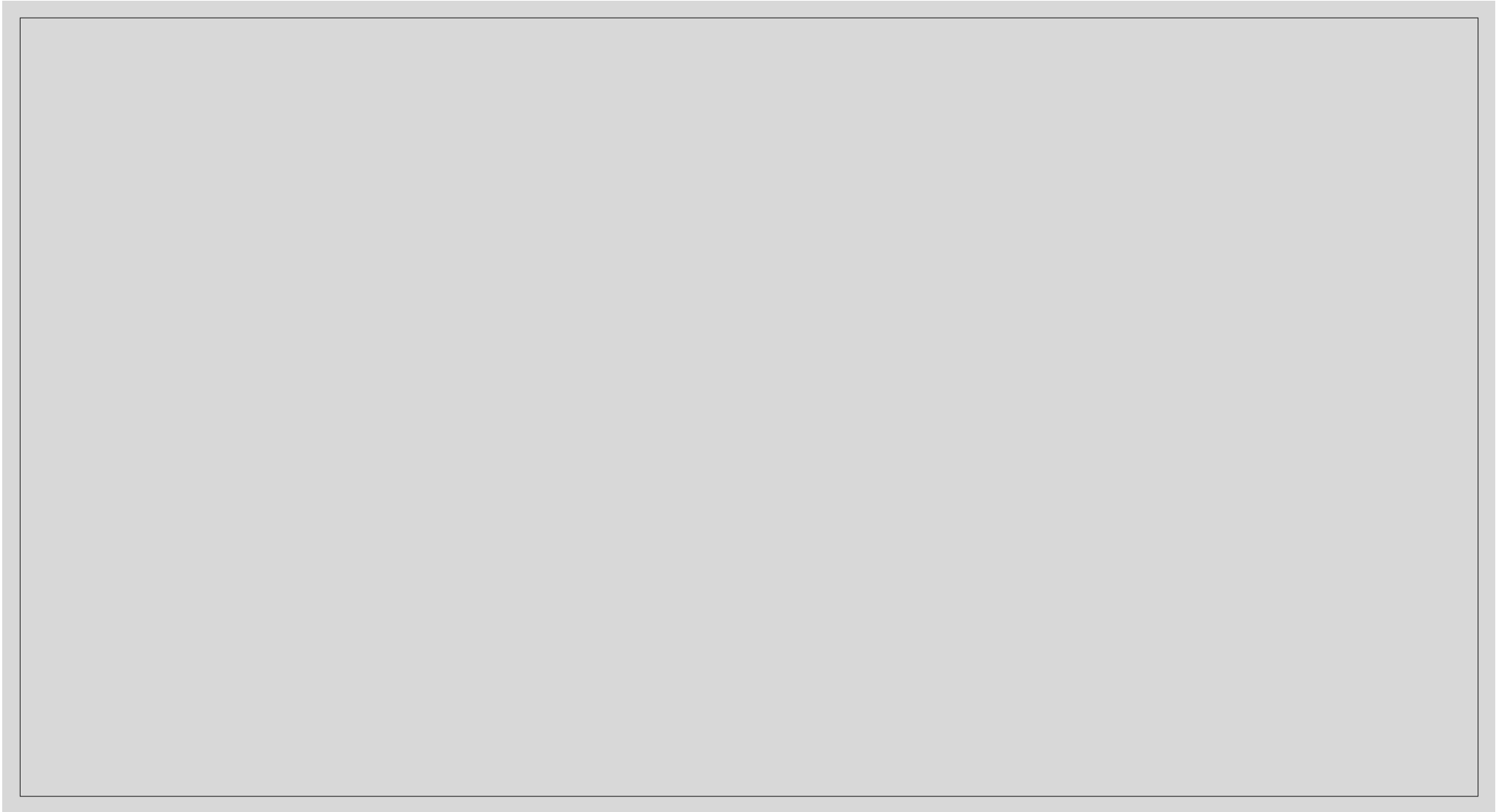

# Cancer Counseling



Understand inherited cancer risk



Order testing



Screening and treatment  
recommendations



Psychosocial implications of test  
results

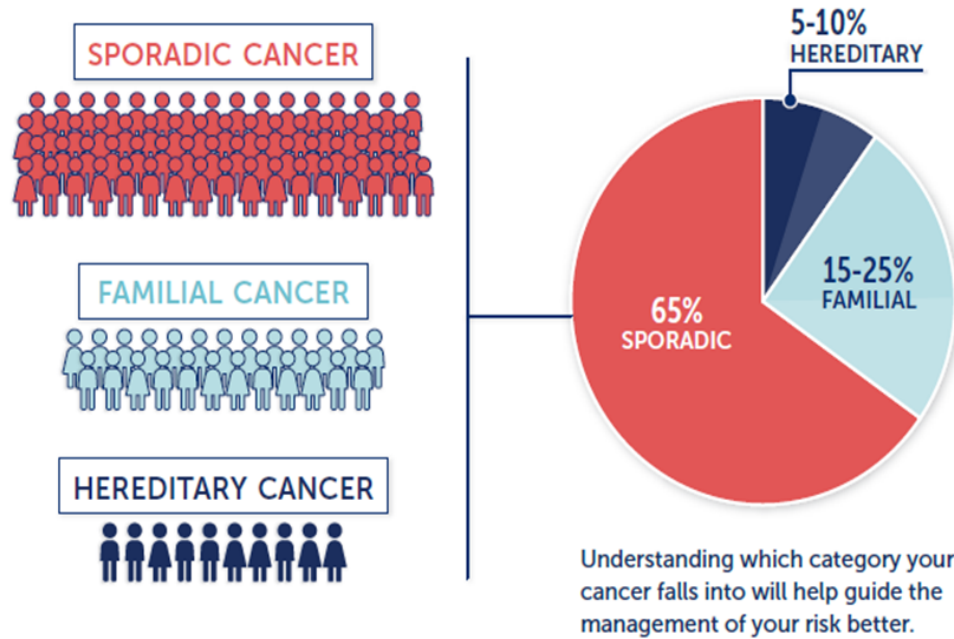

# CANCER GENETICS

## General Genetics/ Pediatrics

- May see children and adults for known or suspected genetic conditions
  - Developmental delay, ASD, neurological disorders, metabolic conditions, vision/hearing disorders, birth defects- spina bifida, cleft palate, CHD
- Usually seen by a genetic counselor and medical geneticist
- Discuss testing options
- Medical Management and Recurrence Risk
- Psychosocial impacts of testing

# Specialties at Emory



Down Syndrome & Fragile X Clinic



22q11.2 Deletion Syndrome Clinic



Bleeding Disorders



Cardiology



Lysosomal Storage Disorders



**Neurology**

**ALS**

**Huntington Disease**

# What to Expect



Sessions can be held in hospitals or out-patient clinics



You'll probably be asked about 3 generations in your family



Facilitated decision making



Non-directiveness

You do NOT have to do genetic testing



Prepare to share your feelings



GCs are usually very friendly and warm

# Genetic Information Non- Disclosure Act

- GINA passed in 2008
- Prohibits discrimination based on genetic information in health insurance and employment
  - Genetic information- family history, test results, genetic counseling, and research participation
- Does not include Long Term Care or Life Insurance

# Pedigrees

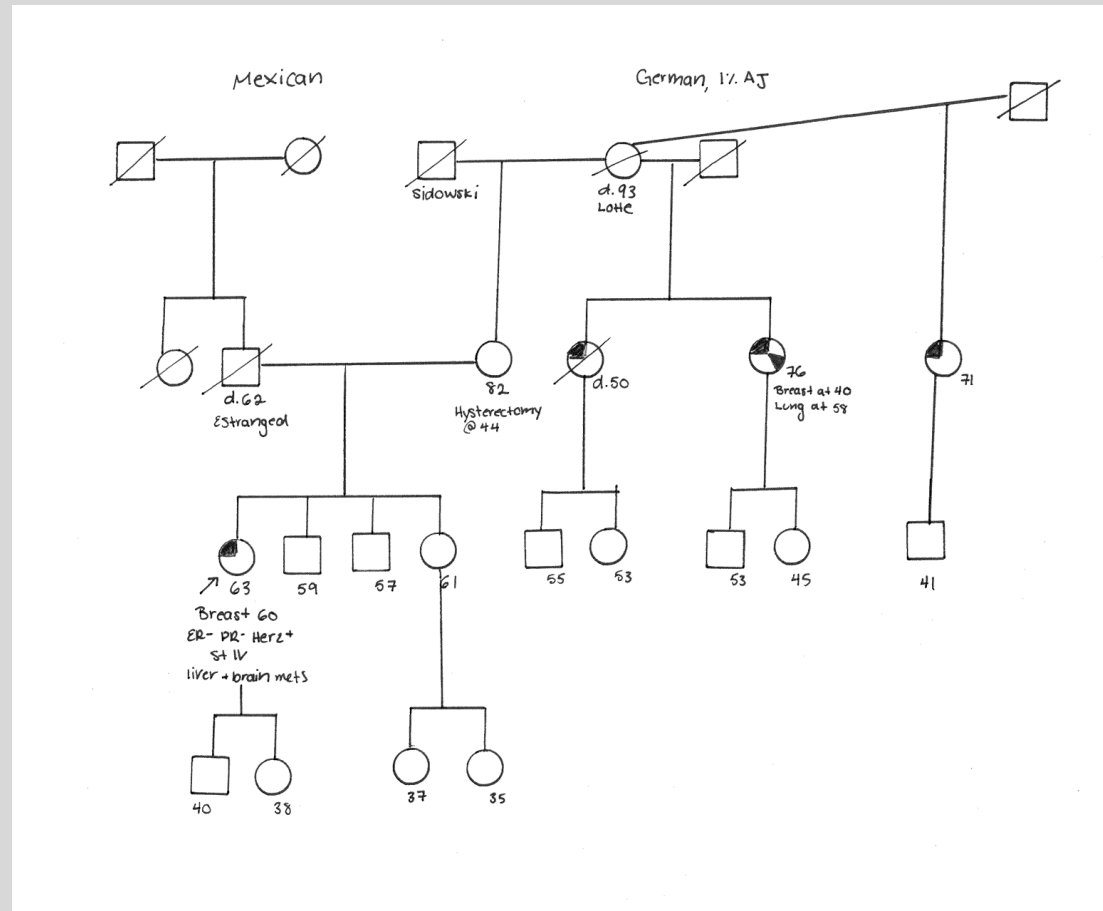

# How to Prepare



Gather information about your family



Compile information about your own health history



Decide who you would like to have come to the session with you



Have your questions ready

## Testing Options

---

Panels

---

Single Gene Test

---

Known Familial Variant

---

Deletions/Duplications

---

Whole Exome Sequencing

# Benefits and Limitations of Genetic Testing

## Benefits

- May lead to a diagnosis
- Some mutations have specific treatments
- Understand inheritance of a condition
- Plan for the future
- GINA
- Empowerment

## Limitations

- We don't know all the genes
- May not find what you're looking for
- Variant of uncertain significance
- Incidental findings
- Combination of nature and environment

# Find a Genetic Counselor

National Society of  
**Genetic  
Counselors**

Login

f t in yt Q

ABOUT US EVENTS PUBLICATIONS NEWSROOM EDUCATION CAREERS JOIN NSGC ADVOCACY COVID-19

[Find a Genetic Counselor](#)

This directory has been developed to assist physicians, patients and genetic counselors in accessing genetic counseling services.

DISCLAIMER  
SEARCH TIPS  
MEET BY PHONE  
MEET IN PERSON  
ABOUT GENETIC COUNSELORS  
PATIENT RESOURCE SITE  
MEMBER DIRECTORY

## In Person - Find a Genetic Counselor

**Search Tips:**

- The "First Name" and "Last Name" fields should only be used if you know the name of the genetic counselor you are looking to contact.
- If you do not return any results within your zip code, try searching just by state.
- Students interested in contacting a genetic counselor about the profession should check the "Student Contact Welcome" box.
- This search includes genetic counselors who offer in-person genetic counseling. To search for a genetic counselor who offers telephone counseling, [click here](#).

[Disclaimer of Warranties and Liabilities](#)

Clear Search Filters

Search For:  Any criteria  Exact criteria

State/Province:

Postal Code:  Within:

Institution/Organization:

Genetic Counselor First Name (optional):

Genetic Counselor Last Name (optional):

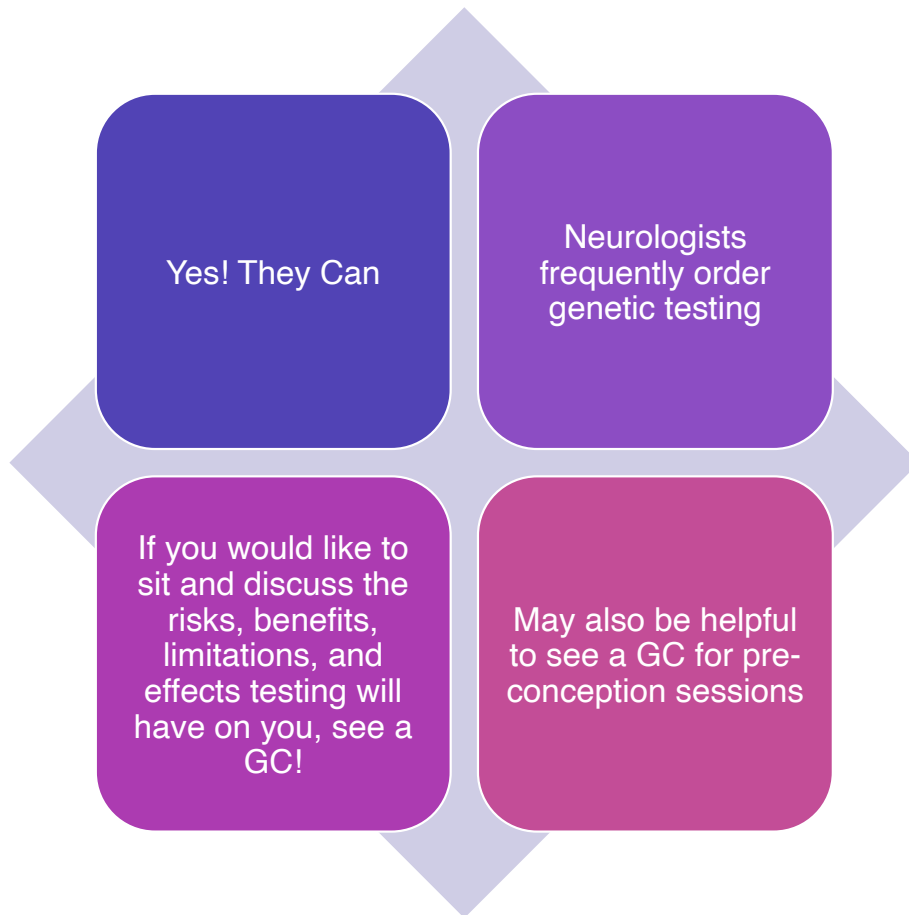

Can't My Doctor Order Genetic Testing?

# Genetic Counseling Research with SCA

Suzy Cahn- first study assessing knowledge and opinions towards reproductive options for patients with SCA

Purpose: Assess participant's knowledge of genetic risk and perceptions of reproductive options

Helpful for Genetic Counselors and other providers to understand perceptions and what is important for this patient group to better serve them

## Patient Interest in Reproductive Options

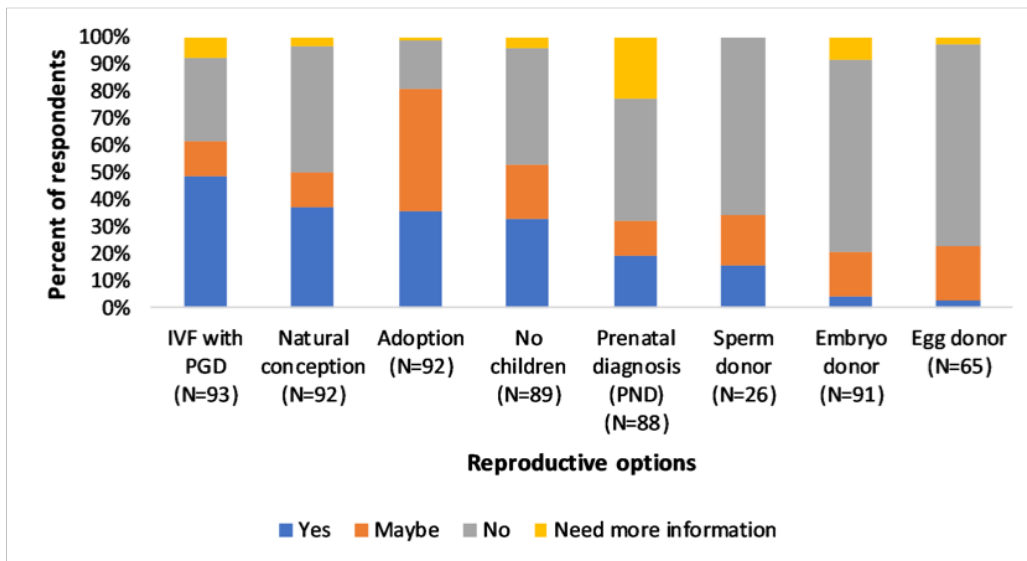

# Current Project

My project will focus on what information SCA patients would like to see on an educational tool

Reasoning behind reproductive option preference

What information is the most valuable

What areas do they not have enough information about



Purpose: to create an educational tool

# To Participate

Contact me!  
Jennifer Pagano

[Jennifer.l.pagano@emory.edu](mailto:Jennifer.l.pagano@emory.edu)

678-557-5613



18-45 years old



Diagnosed SCA



Phone interviews



\$30 Amazon gift card 😊

# Learn More

